

# Service Manual

Finisher, Sorter, DeliveryTray  
**Documnet Insertion Unit-C1**

**Canon**



## Application

This manual has been issued by Canon Inc. for qualified persons to learn technical theory, installation, maintenance, and repair of products. This manual covers all localities where the products are sold. For this reason, there may be information in this manual that does not apply to your locality.

## Corrections

This manual may contain technical inaccuracies or typographical errors due to improvements or changes in products. When changes occur in applicable products or in the contents of this manual, Canon will release technical information as the need arises. In the event of major changes in the contents of this manual over a long or short period, Canon will issue a new edition of this manual.

The following paragraph does not apply to any countries where such provisions are inconsistent with local law.

## Trademarks

The product names and company names used in this manual are the registered trademarks of the individual companies.

## Copyright

This manual is copyrighted with all rights reserved. Under the copyright laws, this manual may not be copied, reproduced or translated into another language, in whole or in part, without the written consent of Canon Inc.

***COPYRIGHT © 2001 CANON INC.***

*Printed in Japan*

## Caution









Use of this manual should be strictly supervised to avoid disclosure of confidential information.

---

# Symbols Used



---

This documentation uses the following symbols to indicate special information:

Symbol	Description
	Indicates an item of a non-specific nature, possibly classified as Note, Caution, or Warning.
	Indicates an item requiring care to avoid electric shocks.
	Indicates an item requiring care to avoid combustion (fire).
	Indicates an item prohibiting disassembly to avoid electric shocks or problems.
	Indicates an item requiring disconnection of the power plug from the electric outlet.
 Memo	Indicates an item intended to provide notes assisting the understanding of the topic in question.
 REF.	Indicates an item of reference assisting the understanding of the topic in question.
	Provides a description of a service mode.
	Provides a description of the nature of an error indication.

The following rules apply throughout this Service Manual:

1. Each chapter contains sections explaining the purpose of specific functions and the relationship between electrical and mechanical systems with reference to the timing of operation.

In the diagrams,  represents the path of mechanical drive; where a signal name accompanies the symbol, the arrow  indicates the direction of the electric signal.

The expression "turn on the power" means flipping on the power switch, closing the front door, and closing the delivery unit door, which results in supplying the machine with power.

2. In the digital circuits, '1' is used to indicate that the voltage level of a given signal is "High", while '0' is used to indicate "Low". (The voltage value, however, differs from circuit to circuit.) In addition, the asterisk (\*) as in "DRMD\*" indicates that the DRMD signal goes on when '0'.

In practically all cases, the internal mechanisms of a microprocessor cannot be checked in the field. Therefore, the operations of the microprocessors used in the machines are not discussed: they are explained in terms of from sensors to the input of the DC controller PCB and from the output of the DC controller PCB to the loads.

The descriptions in this Service Manual are subject to change without notice for product improvement or other purposes, and major changes will be communicated in the form of Service Information bulletins.

All service persons are expected to have a good understanding of the contents of this Service Manual and all relevant Service Information bulletins and be able to identify and isolate faults in the machine."



# Contents

## Chapter 1 Specifications

1.1 Product Specifications .....	1- 1
1.1.1 Specifications .....	1- 1
1.2 Names of Parts .....	1- 2
1.2.1 External view .....	1- 2
1.2.2 Cross Section .....	1- 2

## Chapter 2 Functions

2.1 Basic Construction.....	2- 1
2.1.1 Overview of Electrical Circuitry.....	2- 1
2.2 Basic Operation .....	2- 1
2.2.1 Basic Sequence of Operations .....	2- 1
2.2.2 Drive Path and Arrangement of Sensors.....	2- 2
2.3 Pick-Up/Feed System .....	2- 3
2.3.1 Basic Sequence of Pickup Operations .....	2- 3
2.4 Document Detection .....	2- 7
2.4.1 Detecting the Presence/Absence of an Original.....	2- 7
2.4.2 Checking the Width of the Original .....	2- 7
2.5 Detecting Jams .....	2- 8
2.5.1 Outline .....	2- 8
2.6 Power Supply .....	2- 8
2.6.1 Outline .....	2- 8

## Chapter 3 Parts Replacement Procedure

3.1 Removing from the Host Machine .....	3- 1
3.1.1 Inserter .....	3- 1
3.1.1.1 Removing the Inserter Unit .....	3- 1
3.1.1.2 Removing the Transfer Guide Unit .....	3- 1
3.2 External Covers .....	3- 3
3.2.1 External Covers .....	3- 3
3.2.1.1 Detaching the Rear Cover .....	3- 3
3.2.1.2 Changing the Top Cover Open/Close Angle.....	3- 3
3.2.1.3 Detaching the Front Cover .....	3- 3
3.2.1.4 Changing the Inner Cover Open/Close Angle.....	3- 3
3.3 Drive System .....	3- 4
3.3.1 Pickup Motor.....	3- 4
3.3.1.1 Removing the Tray Pickup Motor.....	3- 4
3.3.2 Feed Motor .....	3- 4
3.3.2.1 Removing the Feed Motor .....	3- 4
3.3.3 Drive Switchover Motor .....	3- 4
3.3.3.1 Removing the Drive Switchover Motor.....	3- 4
3.3.4 Registration Clutch .....	3- 5
3.3.4.1 Removing the Thick Paper Registration Clutch .....	3- 5
3.3.5 Tray Shift Motor .....	3- 5
3.3.5.1 Removing the Lift Motor.....	3- 5
3.4 Document Feeding System .....	3- 7
3.4.1 Pickup Rollor .....	3- 7
3.4.1.1 Removing the Tray A Feed Roller.....	3- 7
3.4.1.2 Removing the Tray B Pickup Roller .....	3- 7

3.4.2 Separation Rollor .....	3- 7
3.4.2.1 Removing the Tray A Separation Roller .....	3- 7
3.4.2.2 Removing the Tray B Separation Roller .....	3- 7
3.4.3 Feed Rollor .....	3- 8
3.4.3.1 Removing the Tray A Feed Roller.....	3- 8
3.4.3.2 Removing the Tray B Feed Roller.....	3- 8
3.4.4 Torque Limiter.....	3- 9
3.4.4.1 Removing the Tray A Torque Limiter.....	3- 9
3.4.4.2 Removing the Tray B Torque Limiter.....	3- 9
3.4.5 Tray Unit .....	3-9
3.4.5.1 Removing the Tray A Unit.....	3- 9
3.4.5.2 Removing the Tray B Unit.....	3- 9
3.5 Electrical System .....	3- 11
3.5.1 Inserter Controller PCB.....	3- 11
3.5.1.1 Removing the Inserter Controller PCB.....	3- 11
3.5.2 LED PCB.....	3- 11
3.5.2.1 Removing the Tray A LED PCB.....	3- 11
3.5.2.2 Removing the Tray B LED PCB.....	3- 11
3.5.3 Sensor.....	3- 12
3.5.3.1 Removing the Tray A Paper Set Sensor.....	3- 12
3.5.3.2 Removing the Tray A Paper Width Sensor .....	3- 12
3.5.3.3 Removing the Tray A Paper Sensor .....	3- 12
3.5.3.4 Removing the Tray A Pickup Sensor .....	3- 13
3.5.3.5 Removing the Tray A Registration Sensor.....	3- 13
3.5.3.6 Removing the Tray B Paper Set Sensor.....	3- 14
3.5.3.7 Removing the Tray B Paper Width Sensor .....	3- 14
3.5.3.8 Removing the Tray B Paper Sensor 1 .....	3- 14
3.5.3.9 Removing the Tray B Paper Sensor 2 .....	3- 15
3.5.3.10 Removing the Tray B Pickup Sensor .....	3- 15
3.5.3.11 Removing the Tray A Lower Limit Sensor.....	3- 16
3.5.3.12 Removing the Tray B Lower Limit Sensor.....	3- 16
3.5.3.13 Removing the Tray B Registration Sensor.....	3- 16
3.5.3.14 Removing the Feed Sensor .....	3- 16
3.5.3.15 Remove the Inserter Open/Close Sensor .....	3- 17
3.5.3.16 Removing the Drive Switchover Sensor.....	3- 17
3.5.3.17 Removing the Top Cover Open/Close Switch.....	3- 17
3.5.3.18 Removing the Feed Sensor 2 .....	3- 17

## Chapter 4 Maintenance

4.1 Maintenance and Inspection .....	4- 1
4.1.1 Periodically Replaced Parts.....	4- 1
4.1.1.1 Periodically Replace Parts.....	4- 1
4.1.2 Durables.....	4- 1
4.1.2.1 Durables.....	4- 1
4.1.3 Periodical Servicing .....	4- 2
4.1.3.1 Scheduled Servicing .....	4- 2
4.2 Adjustment .....	4- 3
4.2.1 Basic Adjustment .....	4- 3
4.2.1.1 Overview .....	4- 3
4.2.1.2 Adjusting the inserter open/close.....	4- 3
4.2.1.3 Adjusting the Height.....	4- 3
4.2.1.4 Adjusting the Document Tray Width .....	4- 4
4.2.1.5 Adjusting the Upper Cover Positioning Pin .....	4- 4
4.3 Outline of Electrical Components .....	4- 6
4.3.1 Sensors.....	4- 6
4.3.2 Motor/ Clutch/ PCB .....	4- 7
4.4 Variable Resistors (VR), Light-Emitting Diodes (LED), and Check Pins by PCB.....	4- 8
4.4.1 Inserter Controller PCB.....	4- 8



---

4.4.2 Explanation of DIP Switch Functions.....	4- 8
4.5 Upgrading .....	4- 11
4.5.1 Upgrading (Inserter Unit) .....	4- 11
 Chapter 5 Error Code	
5.1 Overview.....	5- 1
5.1.1 Overview.....	5- 1
5.2 Service Error Code .....	5- 1
5.2.1 Service Error Code .....	5- 1
5.3 Jam Codes .....	5- 1
5.3.1 Jam Code List.....	5- 1



---

## Chapter 1 Specifications

---



# Contents

1.1 Product Specifications.....	1-1
1.1.1 Specifications.....	1-1
1.2 Names of Parts.....	1-2
1.2.1 External view.....	1-2
1.2.2 Cross Section.....	1-2



## 1.1 Product Specifications

### 1.1.1 Specifications

T-1-1

Item	Description	
Original pickup method	auto pickup/delivery	top separation using separation roller
Original placement	face-up	
Original transport mode	single-sided	
Original type	plain paper, colored paper, coated paper	
Original size	1-bin: small-size (maximum width of 13 inch) 2-bin: small-/large-size (maximum of 13x19.2 inch) width: 182 to 330.2 mm	small-size: A4, A4R, B5, B5R, LTR,LTRR, EXE large-size: A3, B4, LGL, 11"x17"
Original thick	24mm less than	
Stacking capacity	1-bin/2-bin: 200 sheets (80 g/m2)	
Original weight	60g/m2 to 300g/m2	
Placement reference	center	
Original mix	no	
control panel	no	
Display	LED (indicating placement of original)	
Original size detection	yes length: photointerrupters (1-bin: 1 pc.; 2-bin: 2 pc.) width: slide volume (1-bin/2-bin: 1 pc.)	
Outside dimensions (size WXDXH)	Insertor unit: 621mmX679mmX213mm Transfer guide unit: 60mmX492mmX112mm	
Weight	Insertor unit: approx. 17kg Transfer guide unit: approx. 1.5kg	
Power source	by host machine DC24V	
Maximum power	consumption in operation: 103W or less	

## 1.2 Names of Parts

### 1.2.1 External view

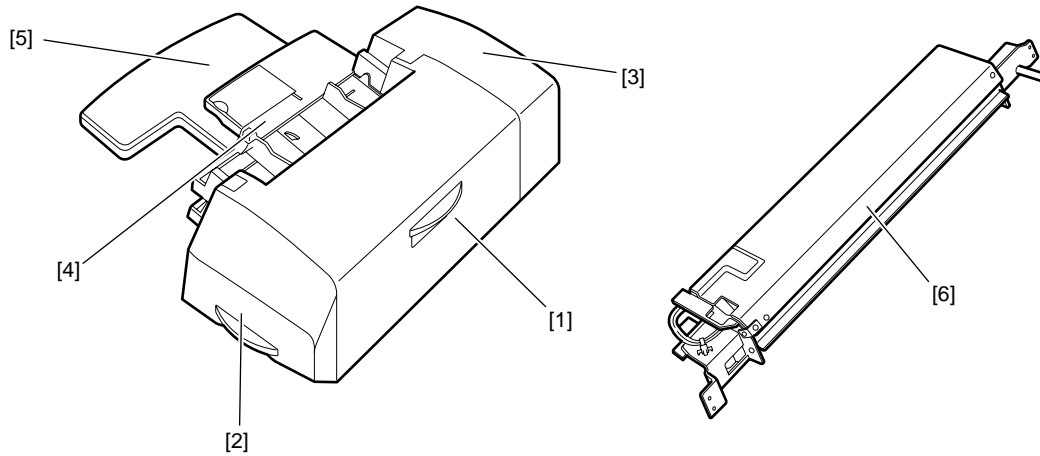

F-1-1  
T-1-2

- [1] Top cover
- [2] Front cover
- [3] Rear cover

- [4] TrayA
- [5] TrayB
- [6] Transfer guide unit

### 1.2.2 Cross Section

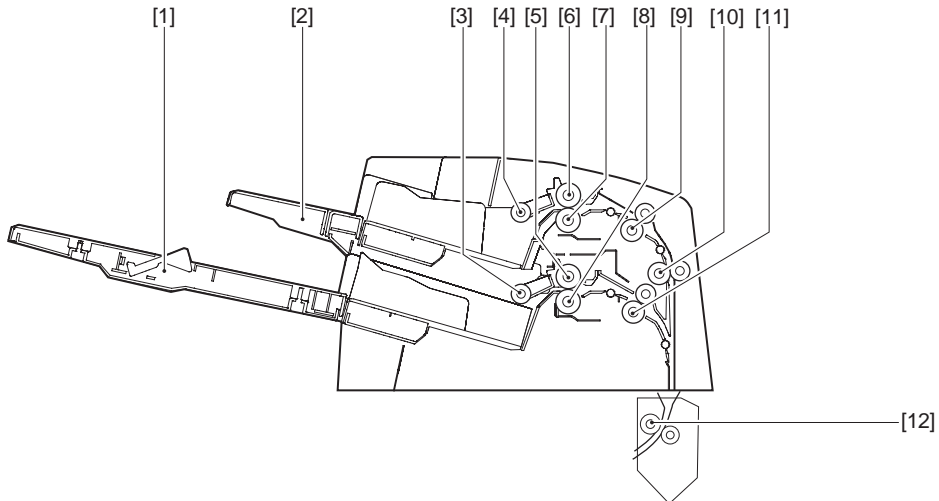

F-1-2

- [1] Tray B
- [2] Tray A
- [3] Tray B pickup roller
- [4] Tray A pickup roller
- [5] Tray B transport roller
- [6] Tray A transport roller

- [7] Tray A separation roller
- [8] Tray B separation roller
- [9] Upper registration roller
- [10] Feed roller 1
- [11] Lower registration roller
- [12] Transfer roller



---

## Chapter 2 Functions

---



---

# Contents

2.1 Basic Construction .....	2-1
2.1.1 Overview of Electrical Circuitry .....	2-1
2.2 Basic Operation .....	2-1
2.2.1 Basic Sequence of Operations .....	2-1
2.2.2 Drive Path and Arrangement of Sensors .....	2-2
2.3 Pick-Up/Feed System .....	2-3
2.3.1 Basic Sequence of Pickup Operations .....	2-3
2.4 Document Detection .....	2-7
2.4.1 Detecting the Presence/Absence of an Original .....	2-7
2.4.2 Checking the Width of the Original .....	2-7
2.5 Detecting Jams .....	2-8
2.5.1 Outline .....	2-8
2.6 Power Supply .....	2-8
2.6.1 Outline .....	2-8



## 2.1 Basic Construction

### 2.1.1 Overview of Electrical Circuitry

The machine's sequence of operations is controlled by the inserter controller PCB. The inserter controller PCB is a CPU (IC7) used to interpret input signals from sensors and host machine and generate signals to drive such loads as motors and clutches at such times as programmed in advance.

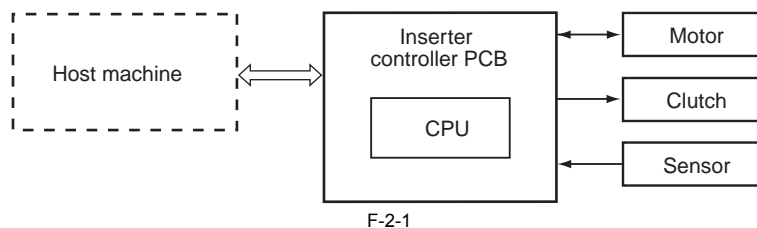

## 2.2 Basic Operation

### 2.2.1 Basic Sequence of Operations

The inserter adds covers and divider sheets to the stack of paper fed from the host machine according to the operation mode set on the host machine. Inserter operation is controlled by the inserter controller PCB using various commands from the host machine. An overview of the inserter operation is provided below.

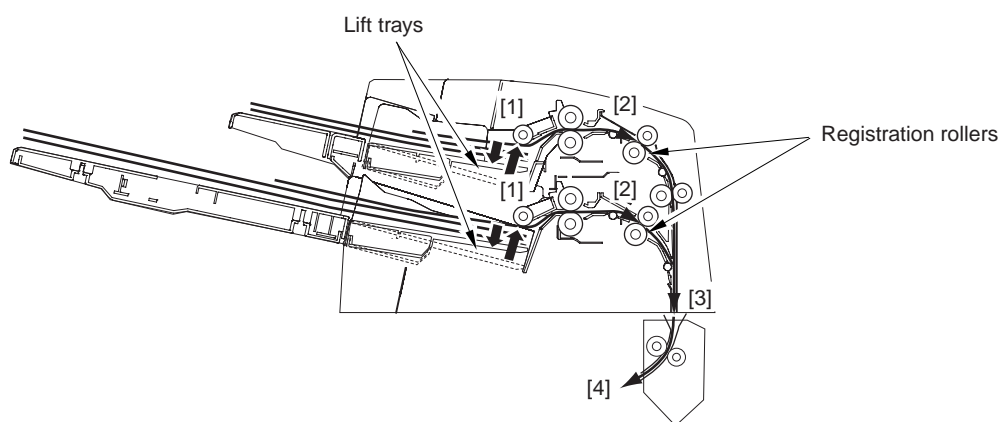

- [1] If there is paper in the lift tray upon receipt of an operation start request from the host machine, the lift tray is pre-lifted up to the position slightly below the position where paper can be picked up.
- [2] Upon receipt of a pickup request from the host machine, paper is supplied from the specified tray to the registration roller (pre-pickup).
- [3] The paper at the pre-pickup position is fed to the standby position.
- [4] Upon receipt of a feed start request from the host machine, the paper at the standby position is fed to the host machine.

2.2.2 Drive Path and Arrangement of Sensors

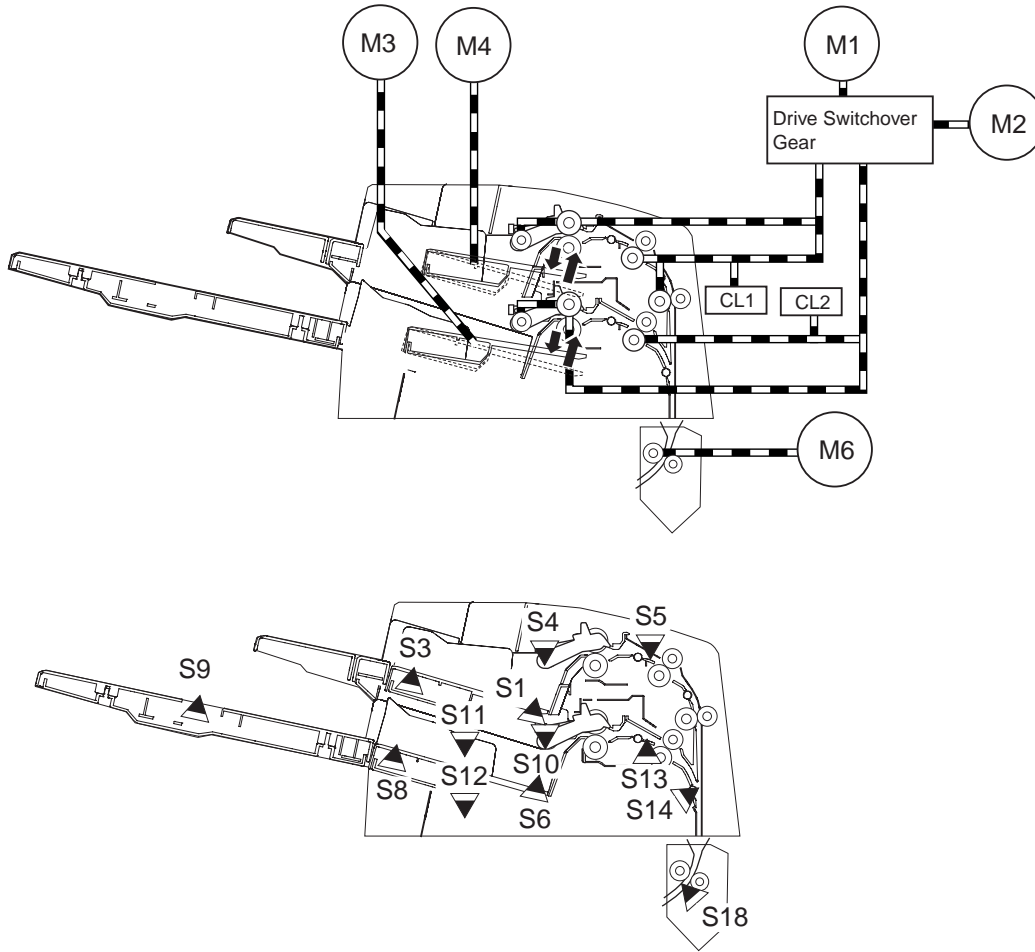

F-2-3

Notation	Name
S1	tray A paper placement sensor
S3	tray A paper sensor
S4	tray A pickup sensor
S5	tray A registration sensor
S6	tray B paper placement sensor
S8	tray B paper sensor 1
S9	tray B paper sensor 2
S10	tray B pickup sensor
S11	tray A lower limit sensor
S12	tray B lower limit sensor
S13	tray B registration sensor
S14	transport sensor
S18	feed sensor 2
M1	tray pickup motor
M2	drive switchover motor
M3	tray A lift motor
M4	tray B lift motor
M6	feed motor
CL1	tray A thick paper registration clutch
CL2	tray B thick paper registration clutch

## 2.3 Pick-Up/Feed System

### 2.3.1 Basic Sequence of Pickup Operations

Upon receipt of a pickup signal from the host machine when paper is present in the tray, paper is picked up as described below. The description below is provided assuming that paper is present in tray A.

#### a. Pre-lifting up

Upon receipt of an operation start request from the host machine when paper is present in the tray and no error/jam has occurred, the lift motor (M4) lifts the tray until the tray pickup sensor (S4) detects the surface of the paper in the tray and then lifts down the tray to the position just above the position where paper can be picked up.

#### Reference:

This function allows you to change paper in the tray because the next job may use a different type of paper in the same tray.

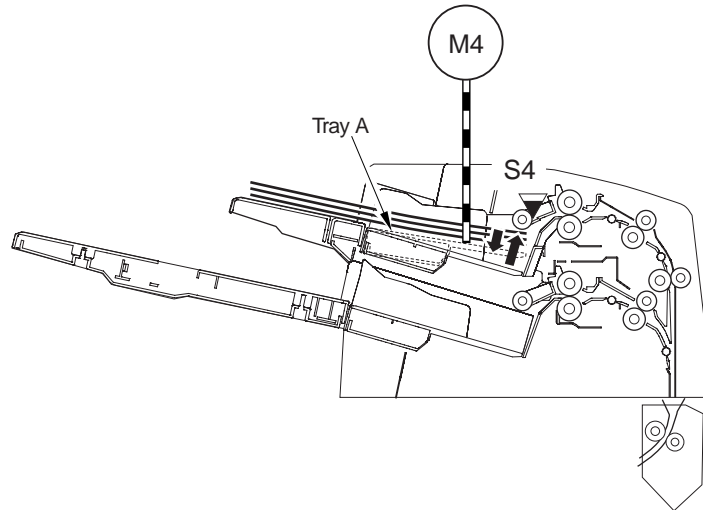

F-2-4

#### b. Pickup drive switchover operation

Upon receipt of a pickup start request from the host machine, the drive switchover motor (M2) is driven to move the switchover gear to the drive gear of the tray that supplies paper according to the ON/OFF state of the pickup switchover sensor (S14). The switchover gear is engaged with the tray A drive gear or tray B drive gear, transferring the drive force of the pickup motor (M1).

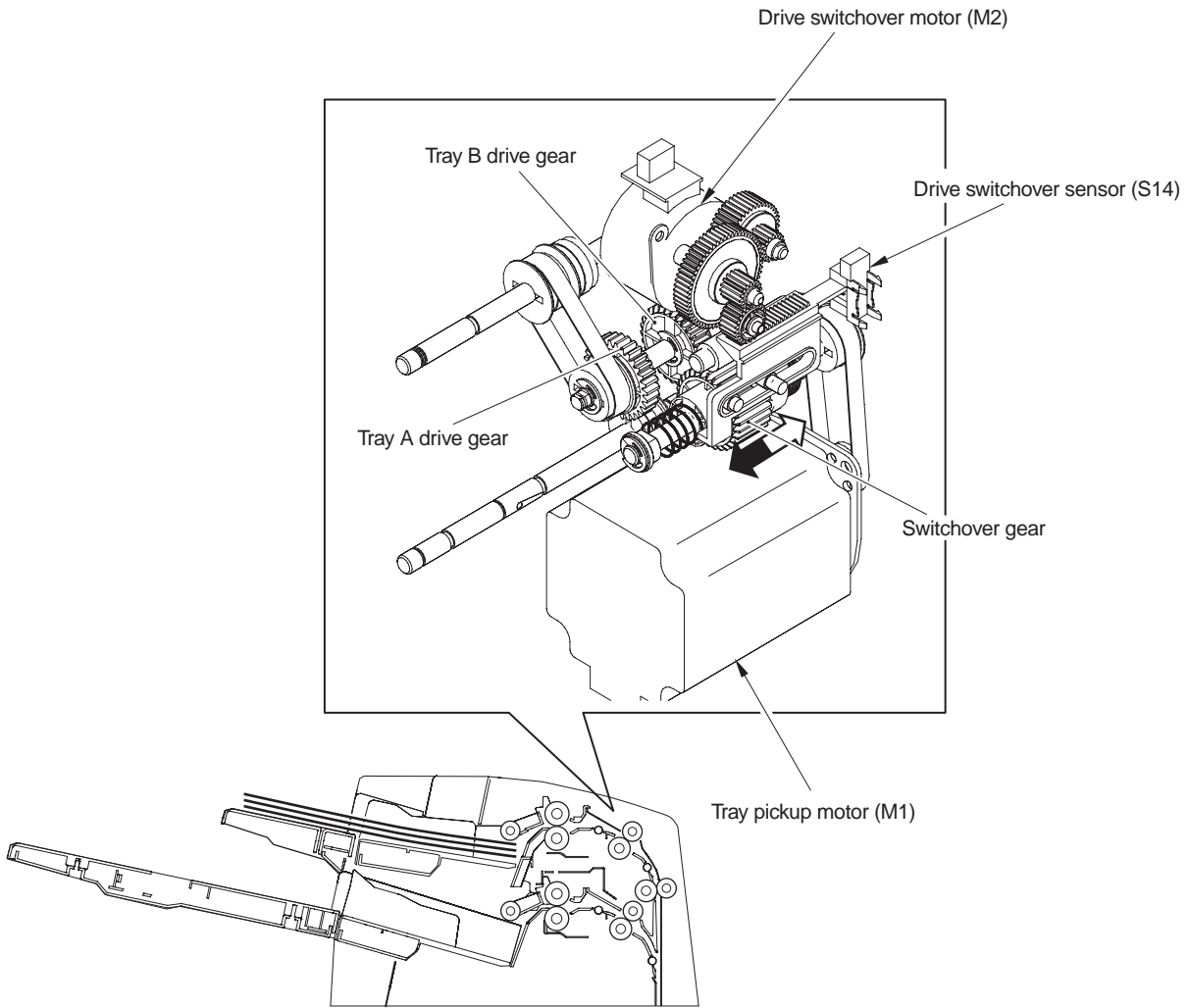

F-2-5

**c. Pre-pickup**

The lift motor (M4) lifts up the tray until the tray pickup sensor (S4) detects the paper surface in the tray. The pickup roller comes in contact with paper. When the pickup motor (M1) turns in the reverse direction, the pickup roller and feed roller rotate to pick up sheets starting with the sheet at the top. The separation roller prevents multiple sheets from being picked up at the same time. The picked up sheet is fed to the registration roller (pre-pickup).

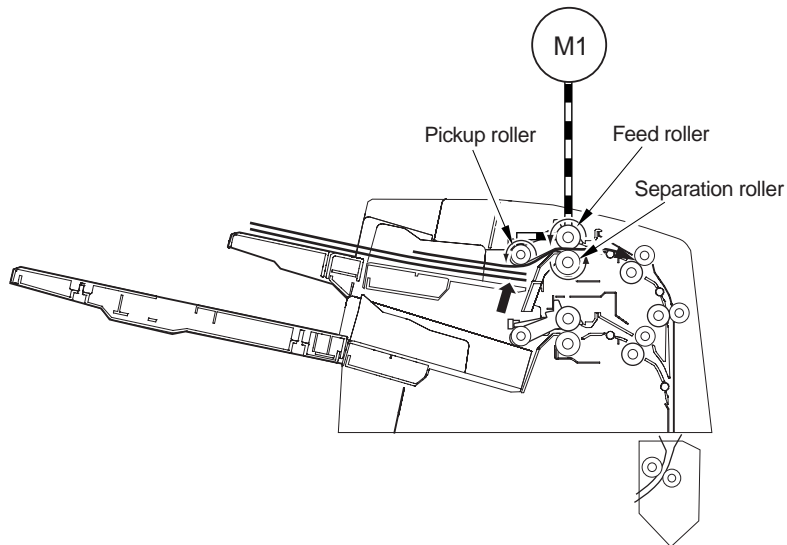

F-2-6

**d. Arching**

After the tray A registration sensor has turned on, the pickup motor stops to press the paper against the registration roller in order to form an arching, thus preventing the paper from skewing.

In the thick paper or coated paper mode, the elastic paper causes the registration roller to move if the roller is not locked, making it hard to for an arching. To solve this problem, the registration clutch (CL1) turns on to lock the registration roller.



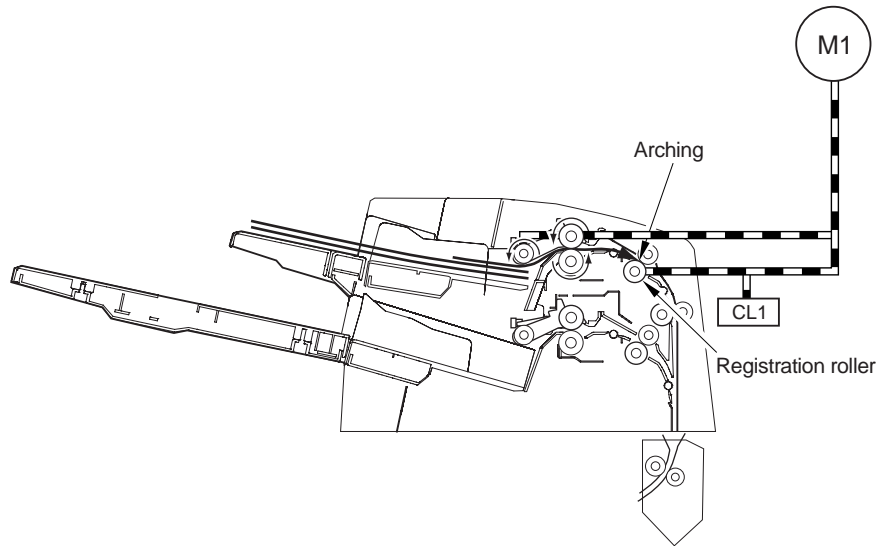

F-2-7

**e. Feed 1**

The pickup motor (M1) turns in the normal direction to feed paper to the standby position using the registration motor and roller 1. When paper arrives at the standby position, the pickup motor (M1) stops.  
(The standby position is 105 mm before the roller which is at the junction with the finisher.)

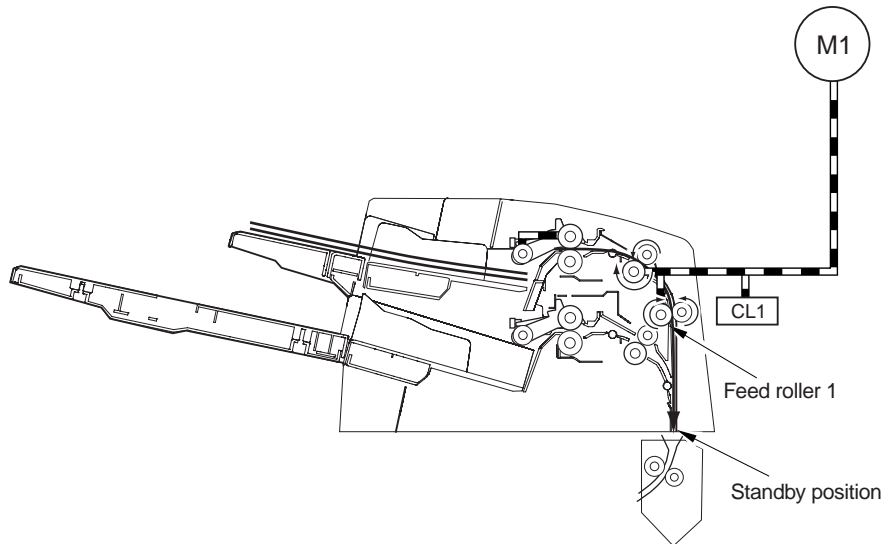

F-2-8

**f. Feed 2**

Upon receipt of a feed start request from the host machine after paper has stopped at the standby position, the pickup motor (M1) and feed motor (M6) turn in the normal direction to feed paper toward the finisher using the feed roller 1 and transfer roller.

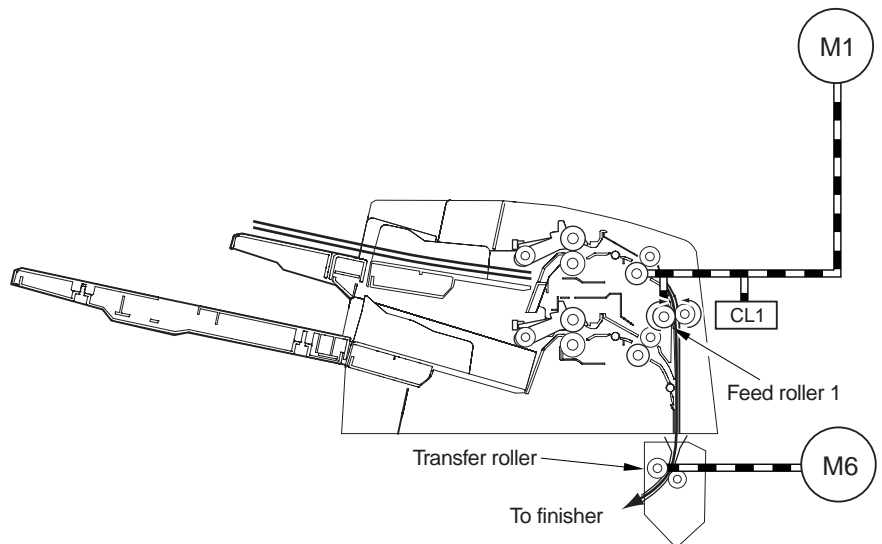

F-2-9

**g. Next Original Pickup**

When the trailing edge of the sheet being picked up has moved 20 mm away from the feed roller 1, the pickup motor (M1) stops. Upon stop of the pickup motor (M1), it starts turning in the reverse direction to pick up the next sheet.  
If the next sheet does is not present, tray A is lifted down. When feed sensor 2 (S18) detects the trailing edge of the sheet, the feed motor stops (M6).

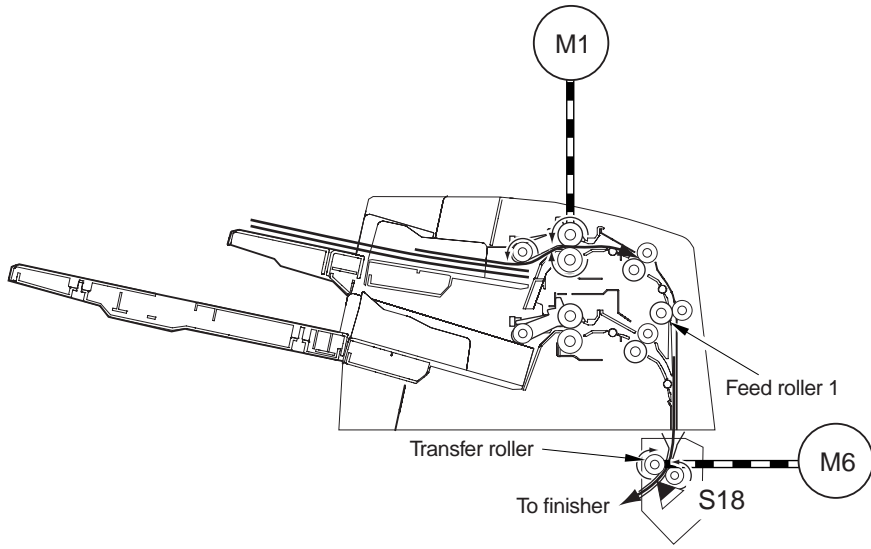

F-2-10

## 2.4 Document Detection

### 2.4.1 Detecting the Presence/Absence of an Original

The presence of paper in the tray A or B is checked by the tray paper placement sensor (S1, S6). When paper is placed in the tray, the detecting lever operates in conjunction with the light-blocking plate, permitting light to reach the photointerrupter and, consequently, causing the tray paper placement sensor (S1, S6) to generate the paper detection signal (1\_EMPS, 2\_EMPS). In response to the paper detection signal (EMPS), the inserter controller PCB turns on the paper placement indicator.

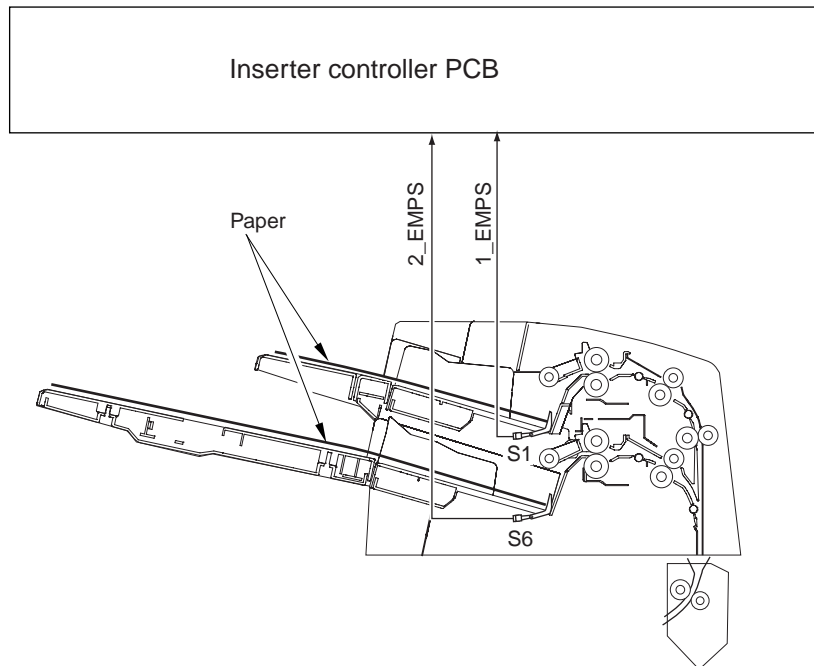

F-2-11

### 2.4.2 Checking the Width of the Original

The size of an original is checked with reference to its width as it is placed in the tray. Its length in feed detection is not checked because of the short paper path.

#### a. Checking the Width of the Original

The width of the original in the tray is checked by the original width sensor (S2, S7) found inside the tray. The original width detecting volume operates in conjunction with the slide guide, causing the resistance to vary (analog). The inserter controller PCB uses the variation in the resistance as the original size signal (VRS), identifying it as indicating the width of the original by conversion.

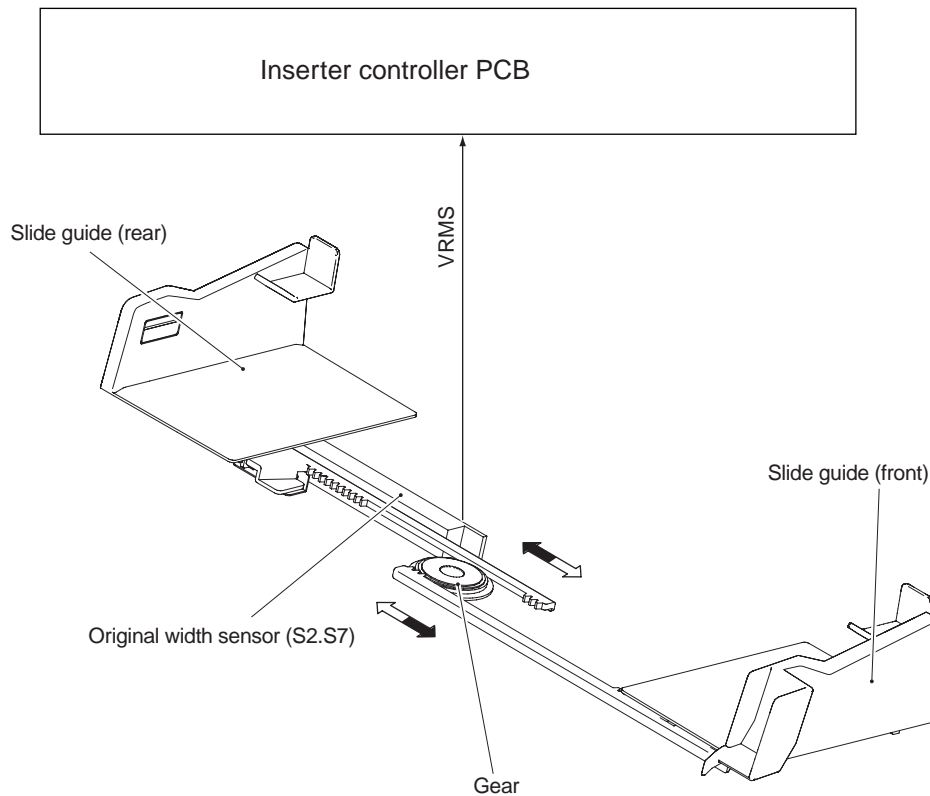

F-2-12

## 2.5 Detecting Jams

### 2.5.1 Outline

The machine is equipped with the following sensors to detect the presence/absence of paper and the movement of paper:

- tray A paper placement sensor (S1)
- tray A paper sensor (S3)
- tray A pickup sensor (S4)
- tray A registration sensor (S5)
- tray B paper placement sensor (S6)
- tray B paper sensor 1 (S8)
- tray B paper sensor 2 (S9)
- tray B pickup sensor (S10)
- tray B registration sensor (S13)
- feed sensor (S14)
- feed sensor 2 (S18)

The machine checks for a jam at such times as programmed in the microprocessor (CPU) on the inserter controller PCB, checking the presence/absence of paper over a specific sensor.

When the CPU detects a jam, the machine will stop all ongoing operations, and indicate the fact to the DC controller of the host machine. When the jam has been removed and all the doors are closed, the inserter controller PCB runs a check to see if the foregoing 11 sensors are on or off. If any of the sensors is on, the machine will assume that the jam has not properly been removed, sending the jam removal signal to the host machine once again.

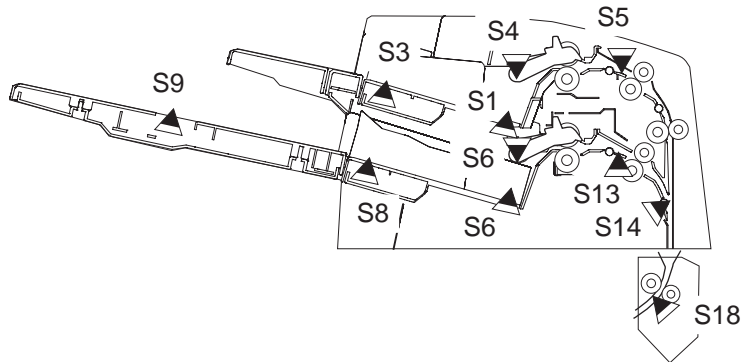

F-2-13

## 2.6 Power Supply

### 2.6.1 Outline

The machine is supplied with 2 systems of power by its host machine: +24V and +5V DC.

The motors and clutches are operated by +24 V, and become deprived of power depending on the state of the upper cover open/closed switch (SW1).

The following is a block diagram of the machine's power supply system:

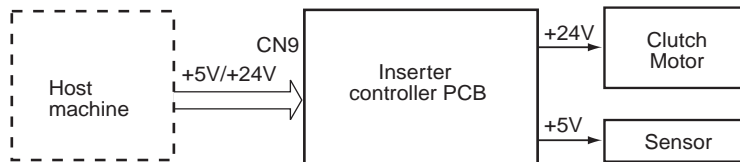

F-2-14

---

## Chapter 3 Parts Replacement Procedure

---



# Contents

3.1 Removing from the Host Machine.....	3-1
3.1.1 Inserter .....	3-1
3.1.1.1 Removing the Inserter Unit.....	3-1
3.1.1.2 Removing the Transfer Guide Unit .....	3-1
3.2 External Covers.....	3-3
3.2.1 External Covers.....	3-3
3.2.1.1 Detaching the Rear Cover .....	3-3
3.2.1.2 Changing the Top Cover Open/Close Angle .....	3-3
3.2.1.3 Detaching the Front Cover .....	3-3
3.2.1.4 Changing the Inner Cover Open/Close Angle .....	3-3
3.3 Drive System.....	3-4
3.3.1 Pickup Motor .....	3-4
3.3.1.1 Removing the Tray Pickup Motor.....	3-4
3.3.2 Feed Motor.....	3-4
3.3.2.1 Removing the Feed Motor .....	3-4
3.3.3 Drive Switchover Motor .....	3-4
3.3.3.1 Removing the Drive Switchover Motor.....	3-4
3.3.4 Registration Clutch .....	3-5
3.3.4.1 Removing the Thick Paper Registration Clutch.....	3-5
3.3.5 Tray Shift Motor .....	3-5
3.3.5.1 Removing the Lift Motor .....	3-5
3.4 Document Feeding System .....	3-7
3.4.1 Pickup Rollor .....	3-7
3.4.1.1 Removing the Tray A Feed Roller .....	3-7
3.4.1.2 Removing the Tray B Pickup Roller.....	3-7
3.4.2 Separation Rollor .....	3-7
3.4.2.1 Removing the Tray A Separation Roller.....	3-7
3.4.2.2 Removing the Tray B Separation Roller.....	3-7
3.4.3 Feed Rollor.....	3-8
3.4.3.1 Removing the Tray A Feed Roller .....	3-8
3.4.3.2 Removing the Tray B Feed Roller .....	3-8
3.4.4 Torque Limiter .....	3-9
3.4.4.1 Removing the Tray A Torque Limiter .....	3-9
3.4.4.2 Removing the Tray B Torque Limiter .....	3-9
3.4.5 Tray Unit.....	3-9
3.4.5.1 Removing the Tray A Unit.....	3-9
3.4.5.2 Removing the Tray B Unit.....	3-9
3.5 Electrical System.....	3-11
3.5.1 Inserter Controller PCB .....	3-11
3.5.1.1 Removing the Inserter Controller PCB .....	3-11
3.5.2 LED PCB .....	3-11
3.5.2.1 Removing the Tray A LED PCB .....	3-11
3.5.2.2 Removing the Tray B LED PCB.....	3-11
3.5.3 Sensor.....	3-12
3.5.3.1 Removing the Tray A Paper Set Sensor.....	3-12
3.5.3.2 Removing the Tray A Paper Width Sensor.....	3-12
3.5.3.3 Removing the Tray A Paper Sensor.....	3-12
3.5.3.4 Removing the Tray A Pickup Sensor.....	3-13
3.5.3.5 Removing the Tray A Registration Sensor .....	3-13
3.5.3.6 Removing the Tray B Paper Set Sensor.....	3-14
3.5.3.7 Removing the Tray B Paper Width Sensor.....	3-14
3.5.3.8 Removing the Tray B Paper Sensor 1 .....	3-14
3.5.3.9 Removing the Tray B Paper Sensor 2 .....	3-15

3.5.3.10 Removing the Tray B Pickup Sensor.....	3-15
3.5.3.11 Removing the Tray A Lower Limit Sensor .....	3-16
3.5.3.12 Removing the Tray B Lower Limit Sensor .....	3-16
3.5.3.13 Removing the Tray B Registration Sensor .....	3-16
3.5.3.14 Removing the Feed Sensor .....	3-16
3.5.3.15 Remove the Inserter Open/Close Sensor .....	3-17
3.5.3.16 Removing the Drive Switchover Sensor.....	3-17
3.5.3.17 Removing the Top Cover Open/Close Switch.....	3-17
3.5.3.18 Removing the Feed Sensor 2 .....	3-17



## 3.1 Removing from the Host Machine

### 3.1.1 Inserter

#### 3.1.1.1 Removing the Inserter Unit

- 1) Remove the rear cover of the inserter.
  - 2) Remove the angle regulating plate [2].
- Screw [1] 2 pc.

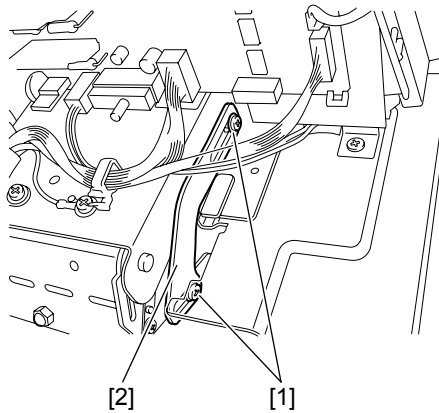

F-3-1

- 3) Detach the rear-right cover of the finisher.
  - 4) Detach the rear-left cover of the finisher.
  - 5) Disconnect the inserter interface cable [1].
- Screw [2] 2 pcs.  
- Connector [3] 3 pcs.  
- Clamp [4] 2 pcs.

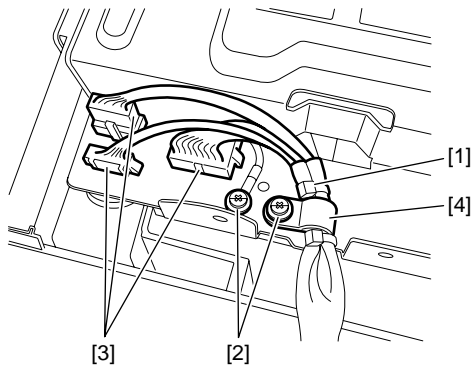

F-3-2

- 6) Slide the inserter unit [1] backward and then lift it to remove.
- Stepped screw [2] 2 pc.

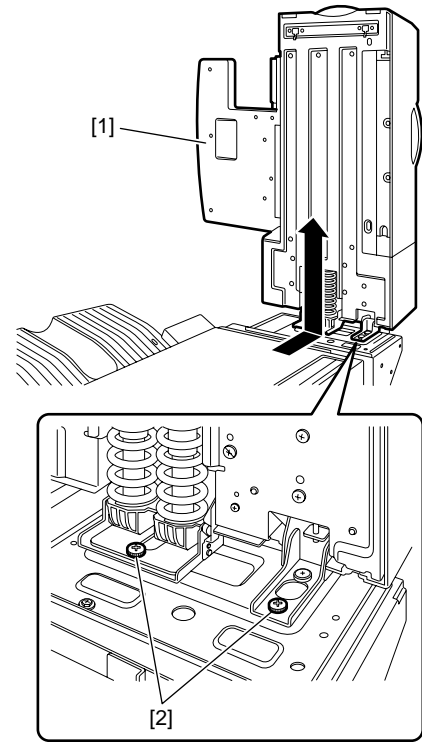

F-3-3

#### 3.1.1.2 Removing the Transfer Guide Unit

- 1) Disconnect the finisher from the host machine.
  - 2) Detach the rear cover of the inserter.
  - 3) Remove the angle regulating plate [2].
- Screw [1] 2 pc.

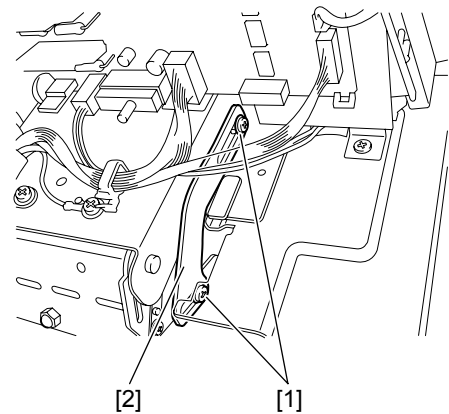

F-3-4

- 4) Detach the rear-right cover of the finisher.
  - 5) Detach the rear-left cover of the finisher.
  - 6) Disconnect the cable [1] of the transfer guide unit.
- Connector [2] 2 pcs.  
- Clamp [3] 2 pcs.

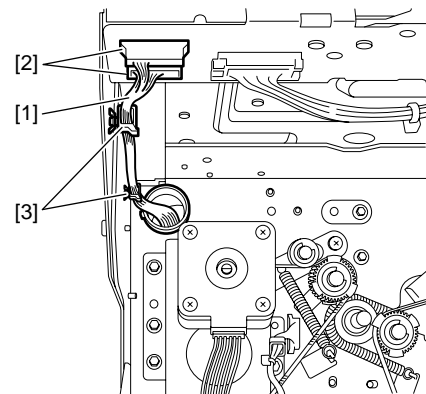

F-3-5

- 7) Open the top cover of the finisher, remove the cable [1] from the round bushing [2], and then remove the transfer guide unit [3].  
- Screw [4] 2 pcs.

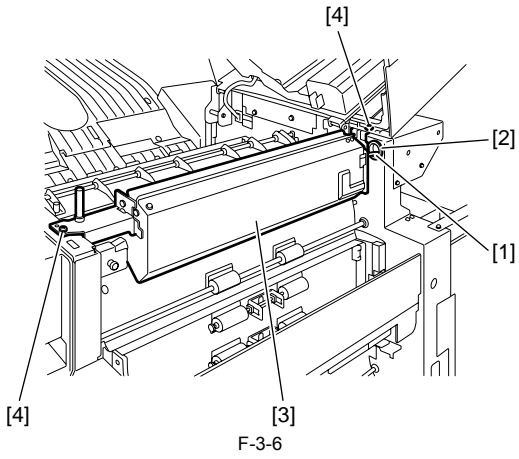

## 3.2 External Covers

### 3.2.1 External Covers

#### 3.2.1.1 Detaching the Rear Cover

- 1) Detach the rear cover [1].
- Screw [2] 2 pcs.

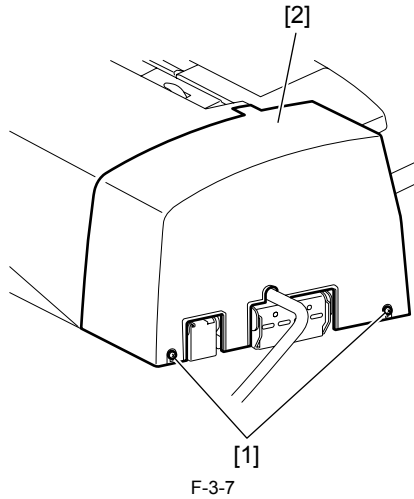

#### 3.2.1.4 Changing the Inner Cover Open/Close Angle

- 1) Detach the rear cover.
- 2) Increase the top cover open/close angle.
- 3) Remove the two screws [1] and open the inner cover [2].

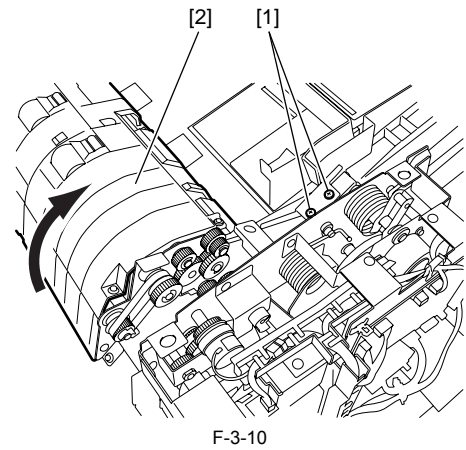

#### 3.2.1.2 Changing the Top Cover Open/Close Angle

- 1) Detach the rear cover.
- 2) Remove the cover angle regulating shaft [1].
- Screw [2] 1 pc.
- 3) Open the top cover.

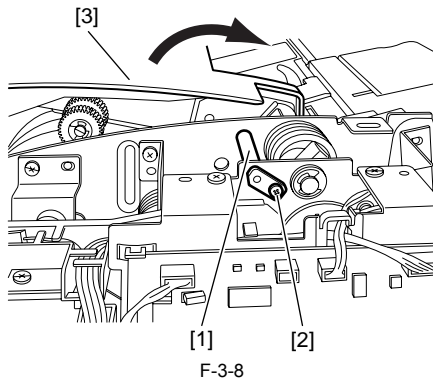

#### 3.2.1.3 Detaching the Front Cover

- 1) Detach the rear cover.
- 2) Increase the open/close angle of the top cover.
- 3) Detach the front cover [1].
- Screw [2] 1 pc.

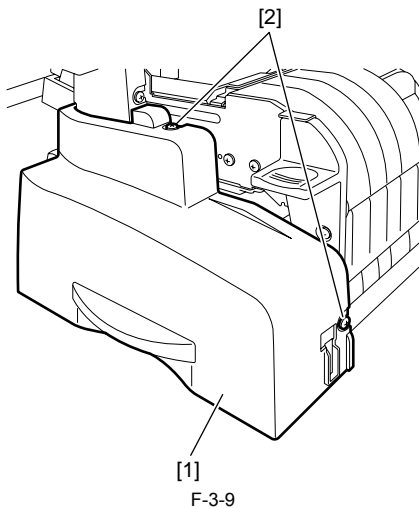

### 3.3 Drive System

#### 3.3.1 Pickup Motor

##### 3.3.1.1 Removing the Tray Pickup Motor

- 1) Detach the rear cover.
- 2) Disconnect the connector [1] of the inserter controller PCB and remove the cable [2] from the harness guide.

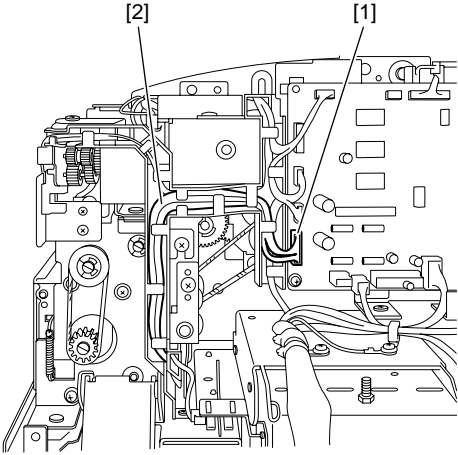

F-3-11

- 3) Remove the pickup motor unit [1].
  - Screw [2] 4 pcs.
  - Belt [3] 1 pc.
  - Spring [4] 1 pc.

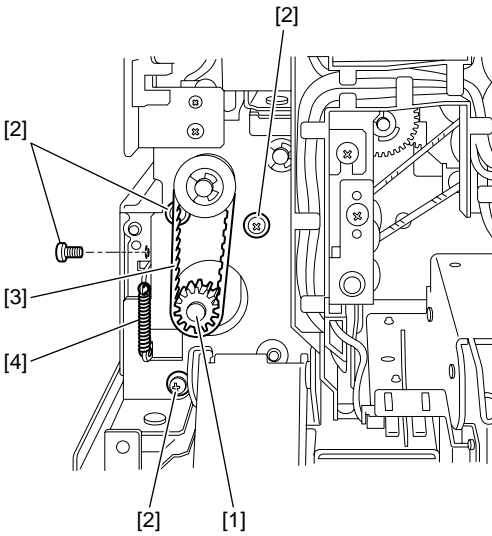

F-3-12

- 4) Remove the pickup motor [1].
  - Screw [2] 2 pcs.
  - Connector [3] 1 pc.

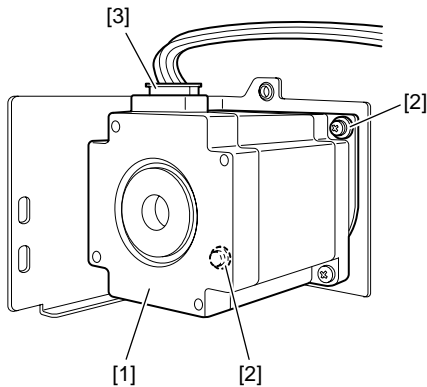

F-3-13

#### 3.3.2 Feed Motor

##### 3.3.2.1 Removing the Feed Motor

- 1) Remove the transfer guide unit.
- 2) Remove the feed motor [1].
  - Screw [2] 2 pcs.
  - Belt [3] 1 pc.

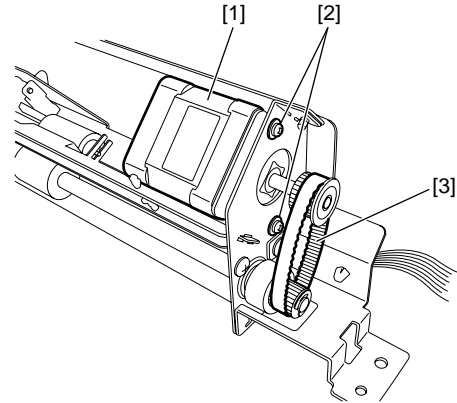

F-3-14

#### 3.3.3 Drive Switchover Motor

##### 3.3.3.1 Removing the Drive Switchover Motor

- 1) Remove the rear cover.
- 2) Remove the inserter controller PCB unit.
- 3) Remove the harness guide [1].
  - Connector [2] 7pcs.
  - Clamp [3] 4pcs.
  - Screw [4] 2pcs.

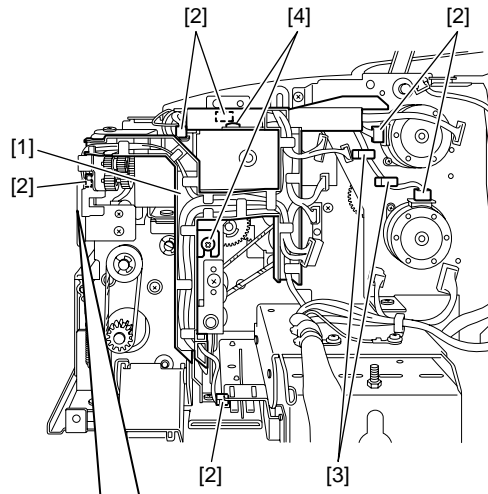

F-3-15

- 4) Remove the 2 screws [1], and detach the drive plate [3] while supporting it so that the 2 bearings [1] will not slip off.

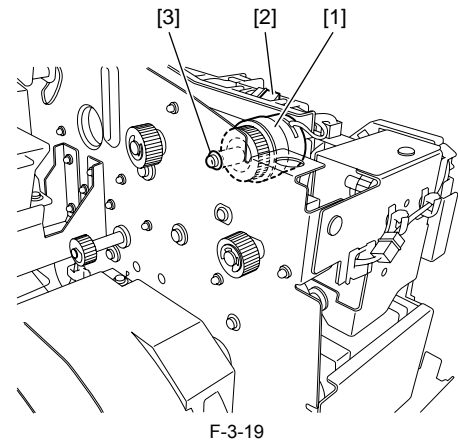
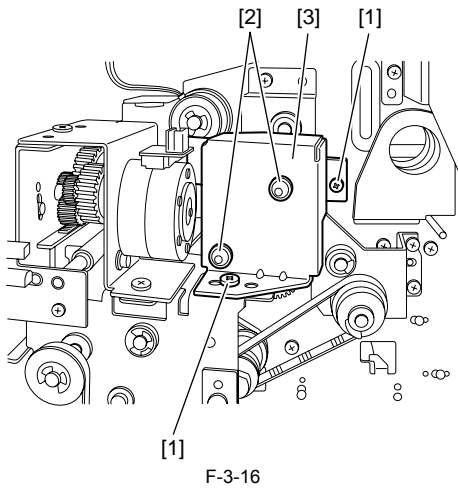

- Tray B thick paper registration clutch



If the drive gear unit [1] (2 pc.) or the belt [2] happens to slip off when the drive plate is being removed, put it in place as follows:

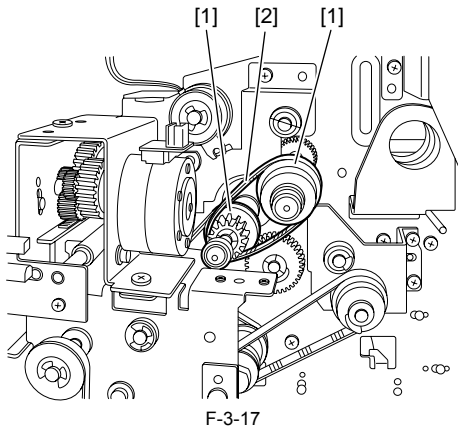

5) Remove the drive switchover motor [1].  
- Screws [2] 2pcs.

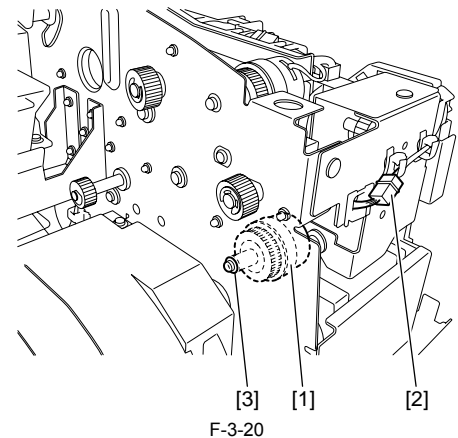

### 3.3.5 Tray Shift Motor

#### 3.3.5.1 Removing the Lift Motor

- 1) Detach the rear cover.
- 2) Remove all connectors from the PCB and remove the inserter controller PCB unit [1].
- Screw [2] 4 pcs.
- Edge saddle [3] 3 pcs.

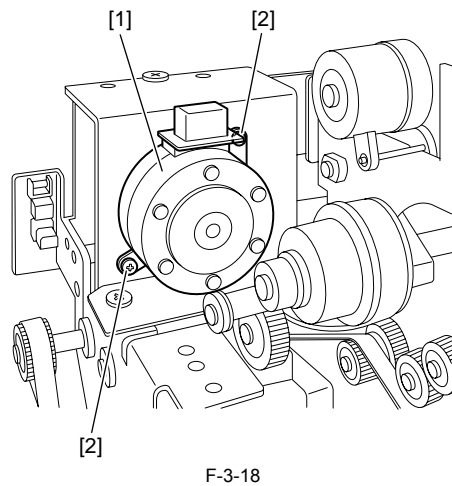

### 3.3.4 Registration Clutch

#### 3.3.4.1 Removing the Thick Paper Registration Clutch

- 1) Detach the rear cover.
- 2) Increase the top cover open/close angle.
- 3) Increase the inner cover open/close angle.
- 4) Remove the thick paper registration clutch [1].
- Connector [2] 1 pc.
- Screw [3] 1 pc.

- Tray A thick paper registration clutch

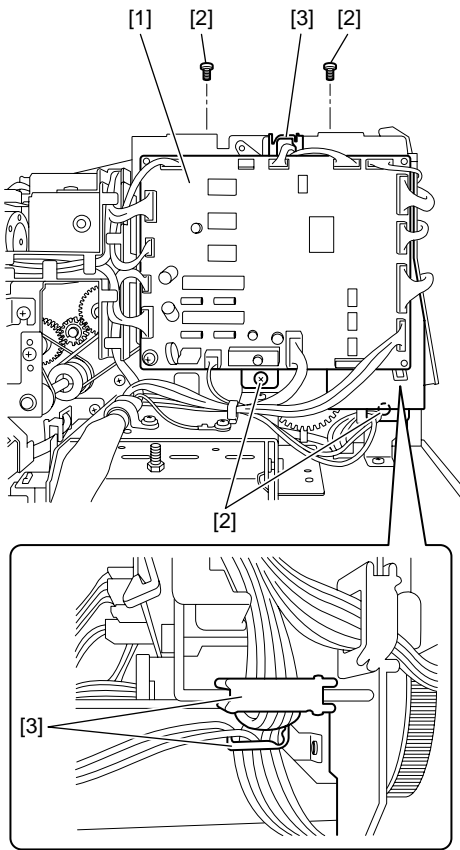

F-3-21

3) Remove the lift motor [1].

- Screw [2] 2 pcs.
- Connector [3] 1 pc.

The upper motor is a tray A lift motor, and the lower motor is a tray B lift motor.

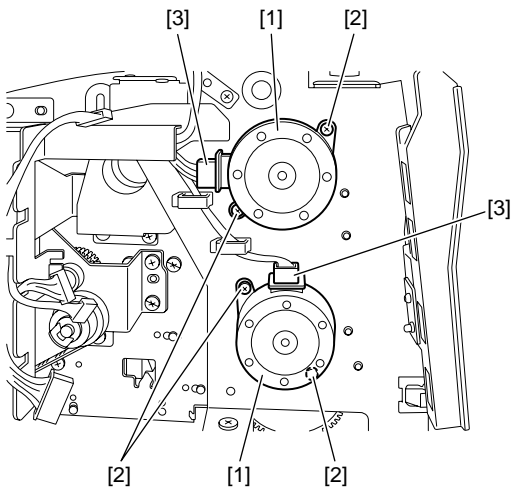

F-3-22

## 3.4 Document Feeding System

### 3.4.1 Pickup Roller

#### 3.4.1.1 Removing the Tray A Feed Roller

- 1) Detach the rear cover.
  - 2) Increase the top cover open/close angle.
  - 3) Remove the feed guide [1].
- Screw [2] 2 pcs.

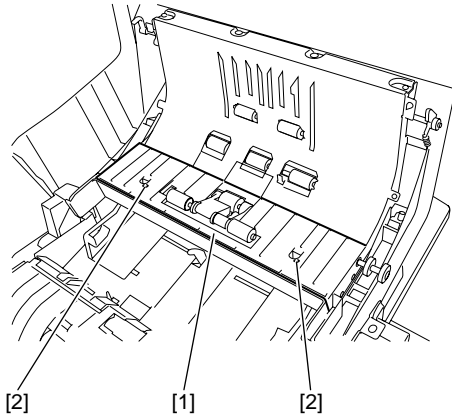

F-3-23

- 4) Remove the two pickup rollers [1].
- Resin E-ring [2] 2 pcs.

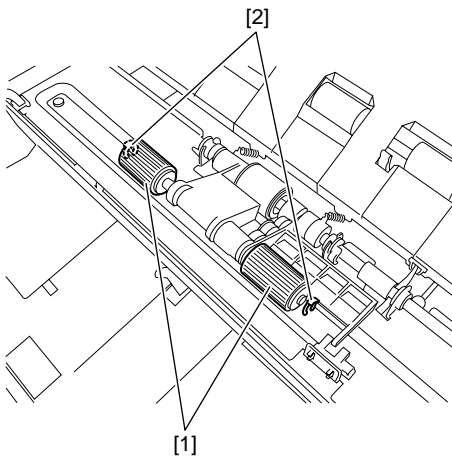

F-3-24

#### 3.4.1.2 Removing the Tray B Pickup Roller

- 1) Detach the rear cover.
  - 2) Increase the top cover open/close angle.
  - 3) Increase the middle cover open/close angle.
  - 4) Remove the two pickup rollers [1].
- Resin E-ring [2] 2 pcs.

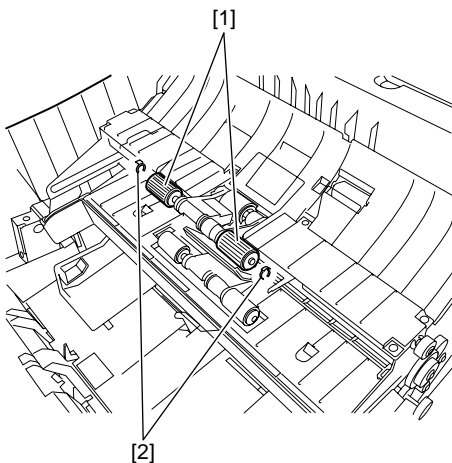

F-3-25

### 3.4.2 Separation Rollor

#### 3.4.2.1 Removing the Tray A Separation Roller

- 1) Detach the rear cover.
  - 2) Increase the top cover open/close angle.
  - 3) Remove the feed guide [1].
- Screw [2] 5 pcs.

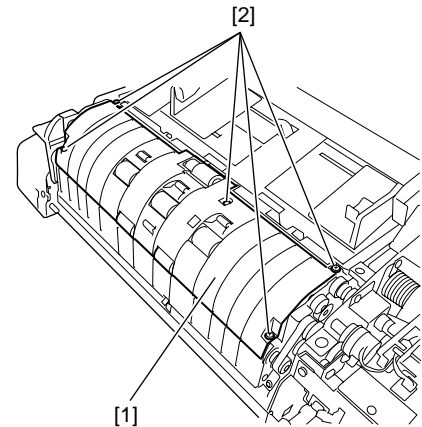

F-3-26

- 4) Remove the tray A separation roller [1].
- E-ring [2] 3 pcs.  
- Gear [3] 1 pc.  
- Parallel pin [4] 1 pc.  
- Bearing [5] 2 pcs.

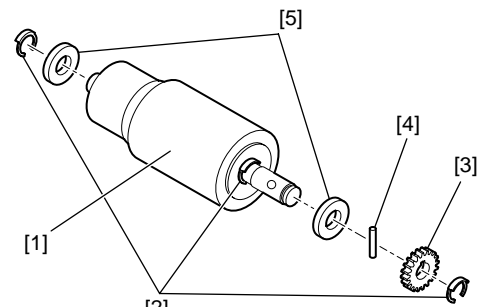

F-3-27

#### 3.4.2.2 Removing the Tray B Separation Roller

- 1) Remove the rear cover.
  - 2) Increase the top cover open/close angle.
  - 3) Increase the middle cover open/close angle.
  - 4) Remove the feed guide [1].
- Screw [2] 5 pcs.

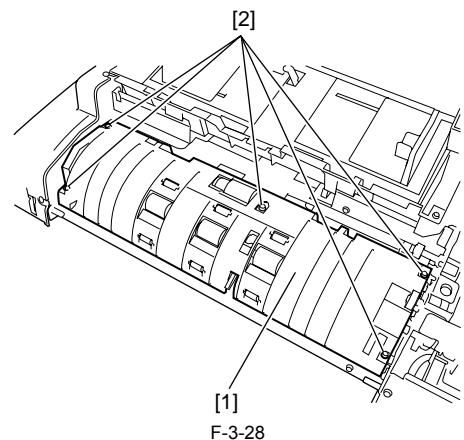

F-3-28

- 5) Remove the tray B separation roller [1].
- E-ring [2] 3 pcs.  
- Gear [3] 1 pc.  
- Parallel pin [4] 1 pc.  
- Bearing [5] 2 pcs.

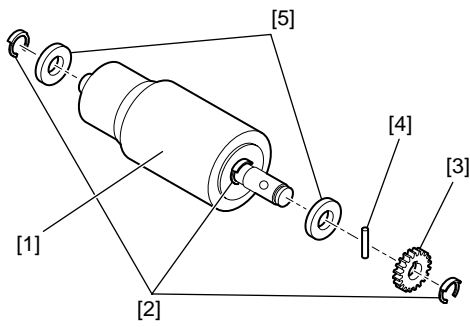

F-3-29

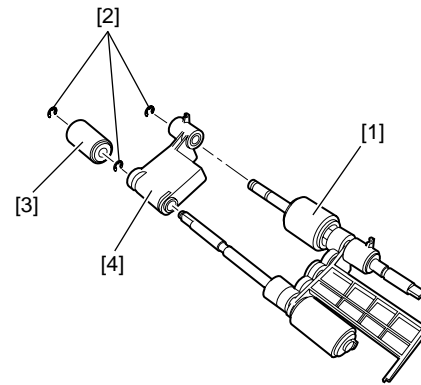

F-3-32

### 3.4.3 Feed Roller

#### 3.4.3.1 Removing the Tray A Feed Roller

- 1) Detach the rear cover.
  - 2) Increase the top cover open/close angle.
  - 3) Remove the front feed guide [1].
- Screw [2] 2 pcs.

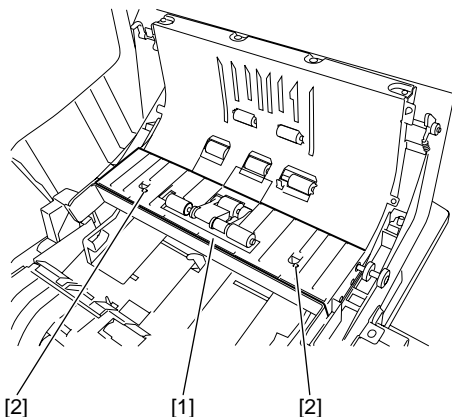

F-3-30

- 4) Remove the pickup roller unit [1].
- Spring [2] 1 pc.  
- Resign E-ring [3] 2 pcs.  
- Bearing [4] 2 pcs.

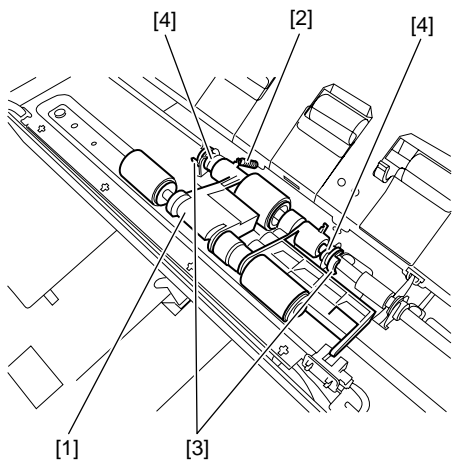

F-3-31

- 5) Remove the tray A feed roller [1].
- E-ring [2] 3 pcs.  
- Pickup roller [3] 1 pc.  
- Lever [4] 1 pc.

#### 3.4.3.2 Removing the Tray B Feed Roller

- 1) Detach the rear cover.
  - 2) Increase the top cover open/close angle.
  - 3) Increase the middle cover open/close angle.
  - 4) Remove the rear feed guide [1].
- Screw [2] 6 pcs.

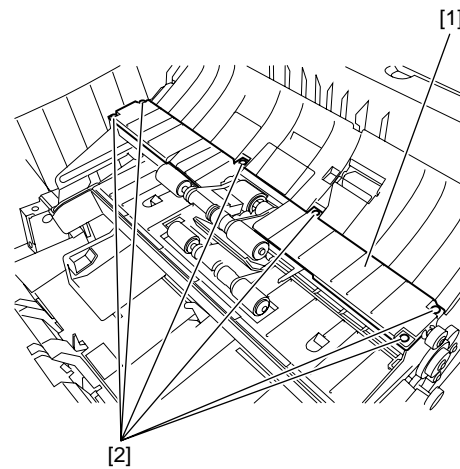

F-3-33

- 5) Remove the pickup roller unit [1].
- Spring [2] 1 pc.  
- Resign E-ring [3] 2 pcs.  
- Bearing [4] 2 pcs.

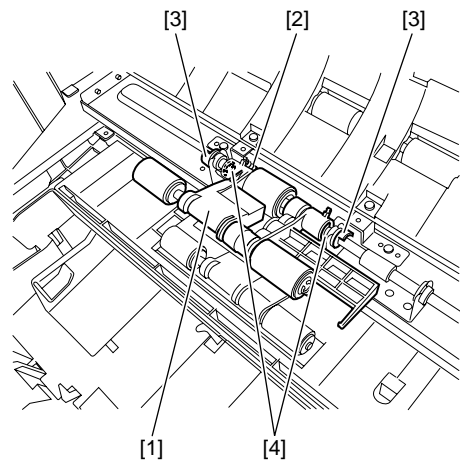

F-3-34

- 6) Remove the tray B feed roller [1].
- E-ring [2] 3 pcs.  
- Pickup roller [3] 1 pc.  
- Lever [4] 1 pc.



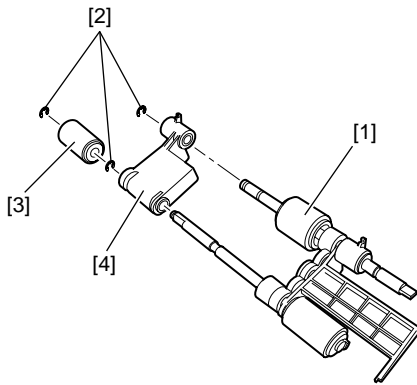

F-3-35

### 3.4.4 Torque Limiter

#### 3.4.4.1 Removing the Tray A Torque Limiter

- 1) Detach the rear cover.
  - 2) Increase the top cover open/close angle.
  - 3) Remove the feed guide [1].
- Screw [2] 5 pcs.

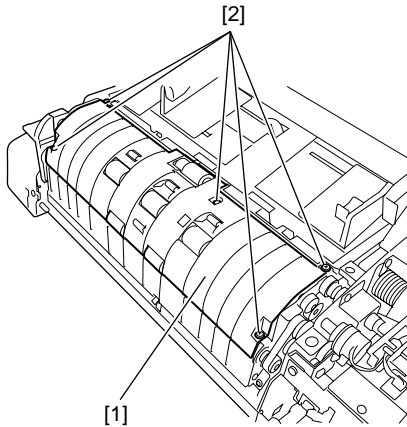

F-3-36

- 4) Remove the tray A torque limiter [1].
- E-ring [2] 3 pcs.
  - Gear [3] 1 pc.
  - Parallel pin [4] 1 pc.
  - Bearing [5] 2 pc.
  - Separation roller [6] 1 pc.

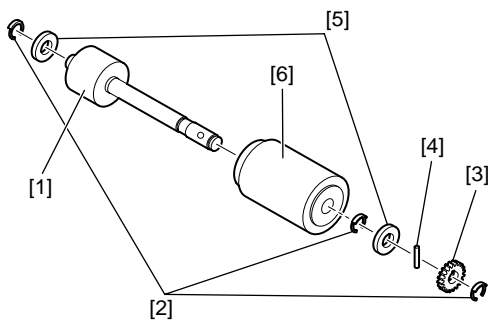

F-3-37

#### 3.4.4.2 Removing the Tray B Torque Limiter

- 1) Detach the rear cover.
  - 2) Increase the top cover open/close angle.
  - 3) Increase the middle cover open/close angle.
  - 4) Remove the feed guide [1].
- Screw [2] 5 pcs.

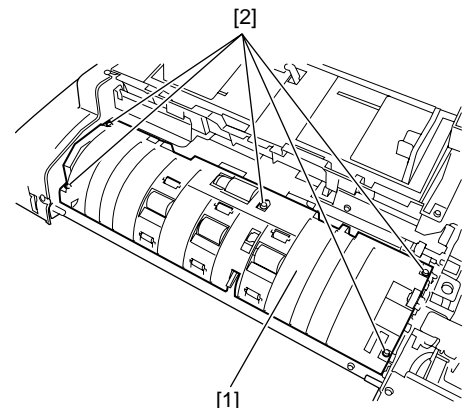

F-3-38

- 5) Remove the tray B torque limiter [1].
- E-ring [2] 3 pcs.
  - Gear [3] 1 pc.
  - Parallel pin [4] 1 pc.
  - Bearing [5] 2 pc.
  - Separation roller [6] 1 pc.

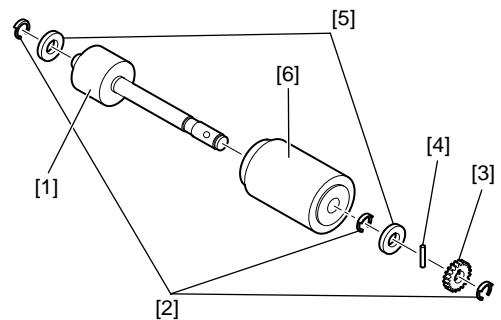

F-3-39

### 3.4.5 Tray Unit

#### 3.4.5.1 Removing the Tray A Unit

- 1) Detach the rear cover.
  - 2) Increase the top cover open/close angle.
  - 3) Detach the front cover.
  - 4) Remove the tray A unit [1].
- Connector [2] 4 pcs. (Connectors CN14/CN17 on the controller and relay connectors)
  - Screw [3] 4 pcs.

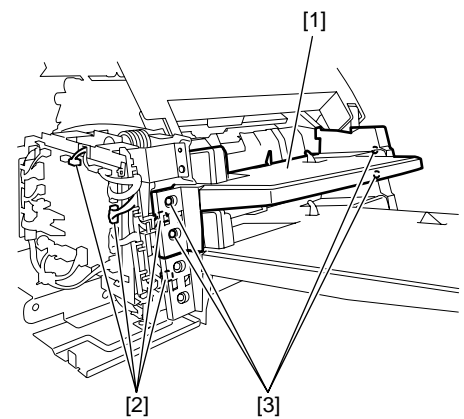

F-3-40

#### 3.4.5.2 Removing the Tray B Unit

- 1) Detach the rear cover.
  - 2) Increase the top cover open/close angle.
  - 3) Detach the front cover.
  - 4) Remove the tray A unit.
  - 5) Remove the tray B unit [1].
- Connector [2] 1 pc.
  - Screw [3] 4 pcs.

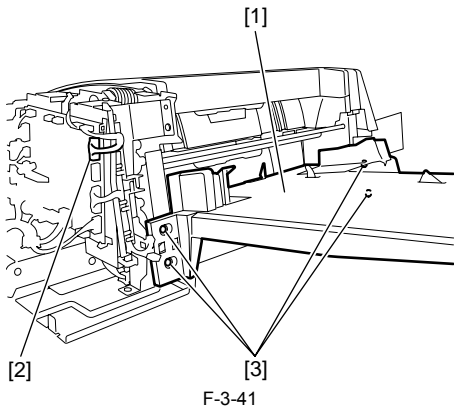

## 3.5 Electrical System

### 3.5.1 Inserter Controller PCB

#### 3.5.1.1 Removing the Inserter Controller PCB

- 1) Detach the rear cover.
  - 2) Disconnect all connectors from the PCB and remove the inserter controller PCB [1].
- Screw [2] 1 pc.  
- Locking support [3] 3 pcs.

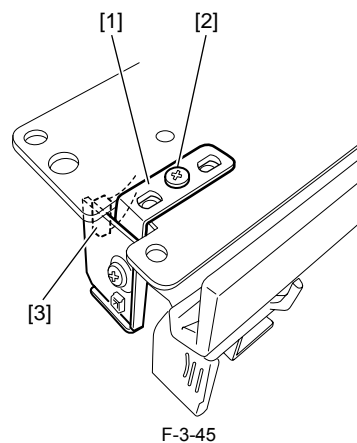
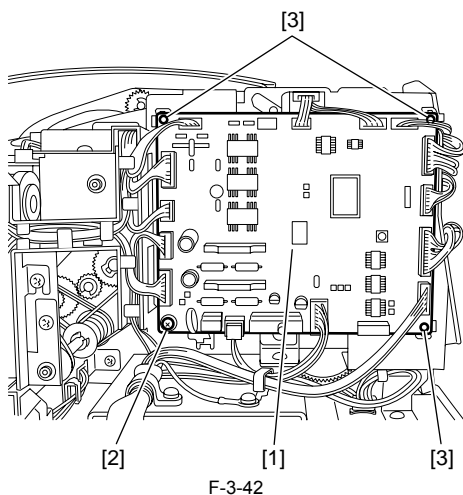

#### 3.5.2.2 Removing the Tray B LED PCB

- 1) Detach the rear cover.
  - 2) Remove the angel regulating shaft and open the top cover.
  - 3) Detach the front cover.
  - 4) Remove the tray A unit.
  - 5) Remove the tray B unit.
  - 6) Detach the tray bottom cover (large) [1].
- Screw [2] 6 pcs.

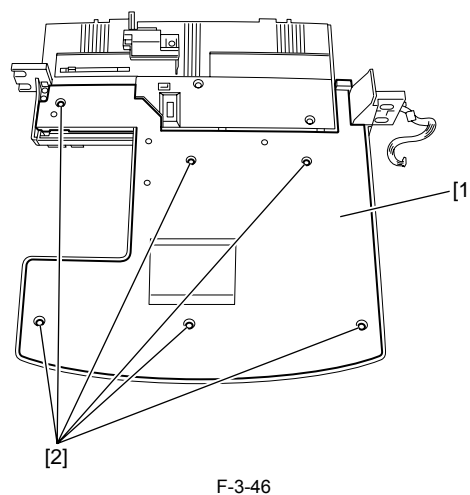

- 7) Detach the LED cover [1].
- Screw [2] 2 pcs.

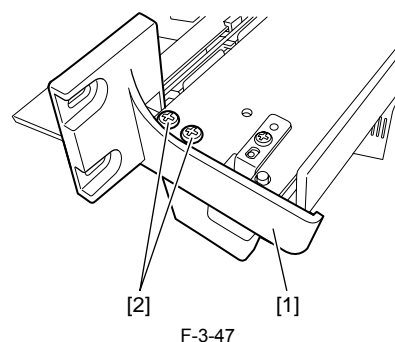

- 8) Remove the tray A paper width sensor [1].
- Screw [2] 1 pc.  
- Connector [3] 1 pc.

### 3.5.2 LED PCB

#### 3.5.2.1 Removing the Tray A LED PCB

- 1) Detach the rear cover.
  - 2) Remove the angel regulating shaft and open the top cover.
  - 3) Detach the front cover.
  - 4) Remove the tray A unit.
  - 5) Detach the tray bottom cover (large) [1].
- Screw [2] 4 pcs.

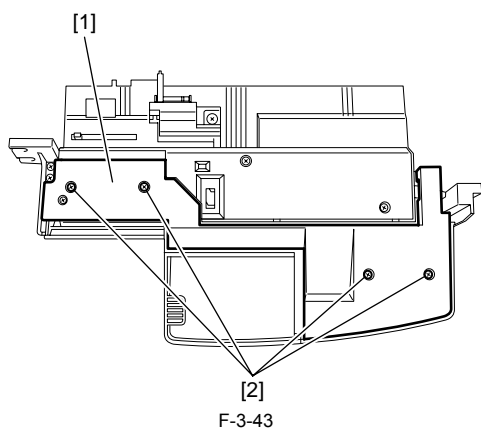

- 6) Detach the LED cover [1].
- Screw [2] 2 pcs.

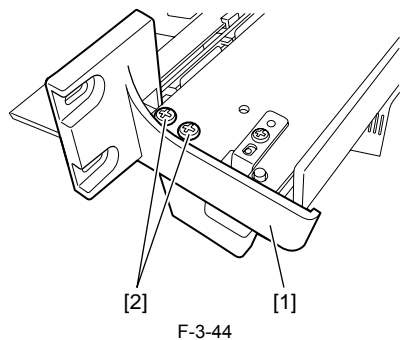

- 7) Remove the tray A paper width sensor [1].
- Screw [2] 1 pc.  
- Connector [3] 1 pc.

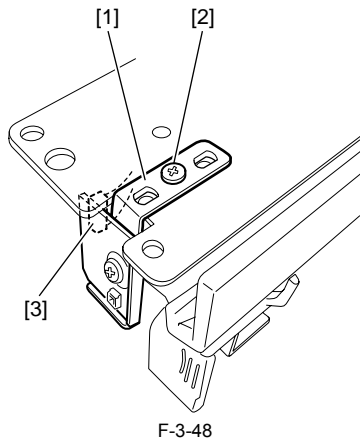

F-3-48

### 3.5.3 Sensor

#### 3.5.3.1 Removing the Tray A Paper Set Sensor

- 1) Detach the rear cover.
  - 2) Increase the top cover open/close angle.
  - 3) Detach the front cover.
  - 4) Remove the tray A unit.
  - 5) Detach the sensor cover [1].
- Screw [2] 1 pc.

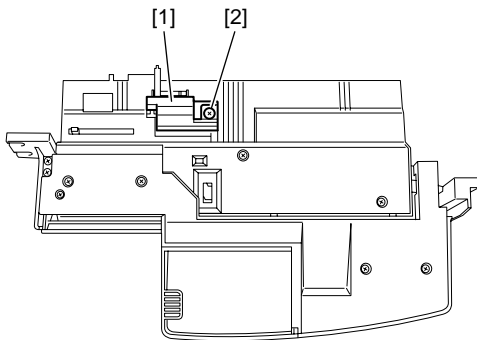

F-3-49

- 6) Remove the tray A paper set sensor [1].
- Connector [2] 1 pc.

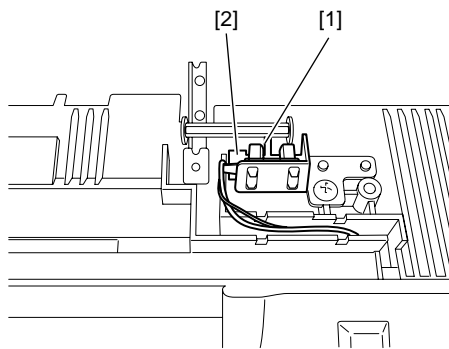

F-3-50

#### 3.5.3.2 Removing the Tray A Paper Width Sensor

- 1) Detach the rear cover.
  - 2) Increase the top cover open/close angle.
  - 3) Detach the front cover.
  - 4) Remove the tray A unit.
  - 5) Detach the tray bottom cover (small) [1].
- Screw [2] 2 pcs.
- 6) Detach the tray bottom cover (large) [3].
- Screw [4] 4 pcs.

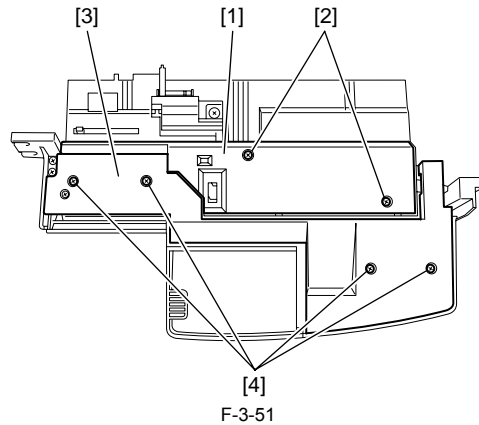

F-3-51

- 7) Remove the tray A paper width sensor [1].
- Screw [2] 2 pcs.  
- Screw [3] 1 pc.

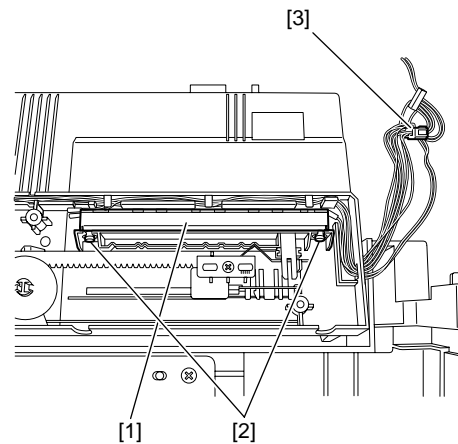

F-3-52



After replacing with the tray A paper width sensor with a new one, adjust the sensor output value in the service mode.

#### 3.5.3.3 Removing the Tray A Paper Sensor

- 1) Detach the rear cover.
  - 2) Increase the top cover open/close angle.
  - 3) Detach the front cover.
  - 4) Remove the tray A unit.
  - 5) Detach the tray bottom cover (small) [1].
- Screw [2] 2 pcs.

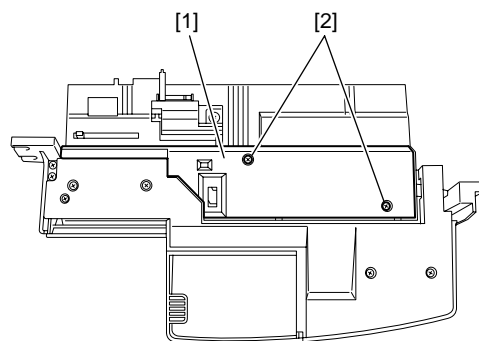

F-3-53

- 6) Remove the tray A paper sensor [1].
- Connector [2] 1 pc.

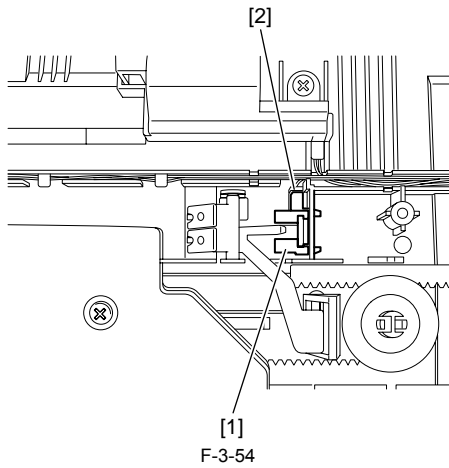

### 3.5.3.4 Removing the Tray A Pickup Sensor

- 1) Detach the rear cover.
  - 2) Increase the top cover open/close angle.
  - 3) Remove the front transfer guide [1].
- Screw [2] 2 pcs.

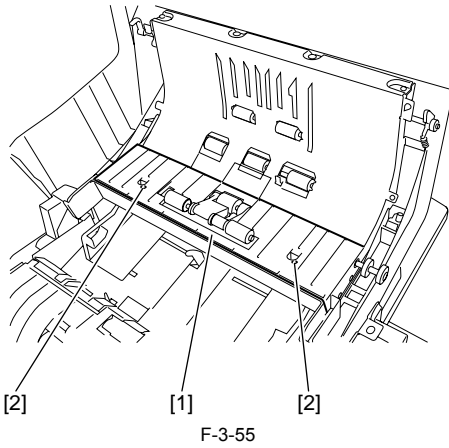

- 4) Remove the tray A pickup sensor [1].
- Connector [2] 1 pc.

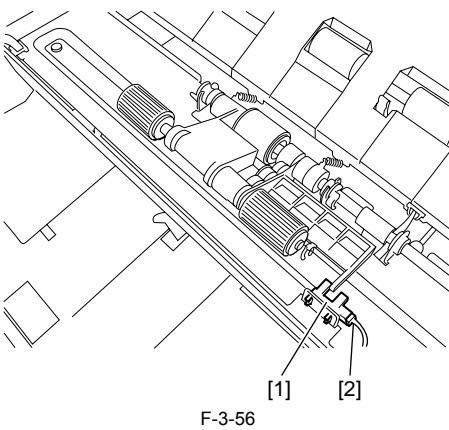

### 3.5.3.5 Removing the Tray A Registration Sensor

- 1) Detach the rear cover.
  - 2) Increase the top cover open/close angle.
  - 3) Remove the front feed guide [1].
- Screw [2] 2 pcs.

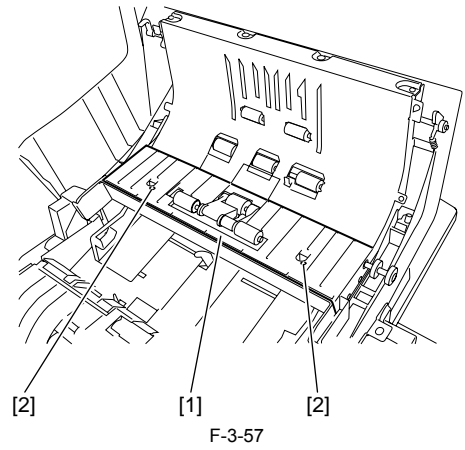

- 4) Remove the feed guide plate [1].
- Screw [2] 8 pcs.  
- Screw [3] 1 pc.

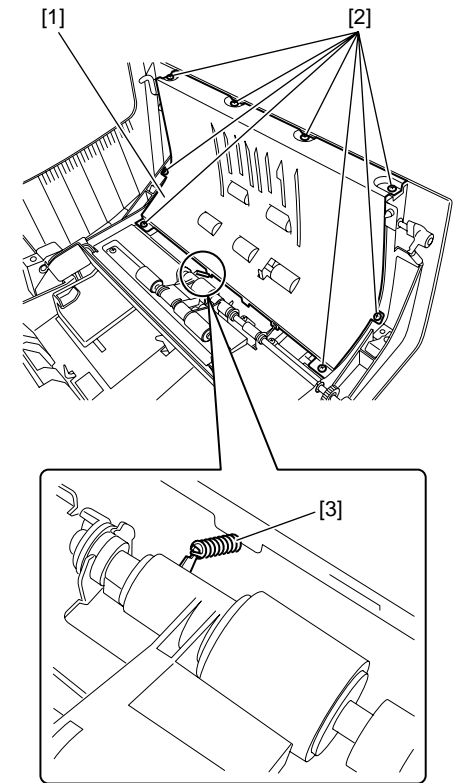

- 5) Remove the tray A registration sensor [1].
- Connector [2] 1 pc.

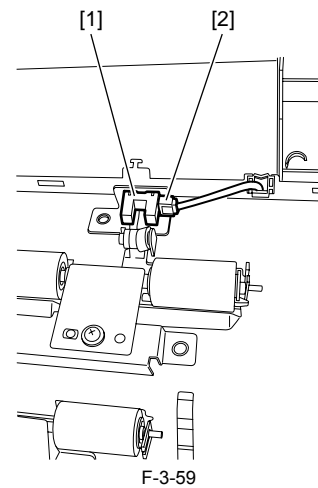

### 3.5.3.6 Removing the Tray B Paper Set Sensor

- 1) Remove the rear cover.
  - 2) Increase the top cover open/close angle.
  - 3) Detach the front cover.
  - 4) Remove the tray A unit.
  - 5) Remove the tray B unit.
  - 6) Detach the sensor cover [1].
- Screw [2] 1 pc.

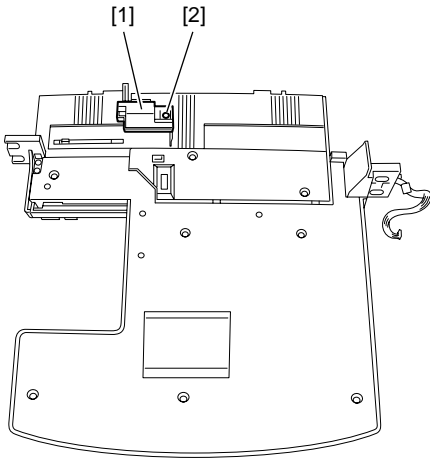

F-3-60

- 7) Remove the tray B paper set sensor [1].
- Connector [2] 1 pc.

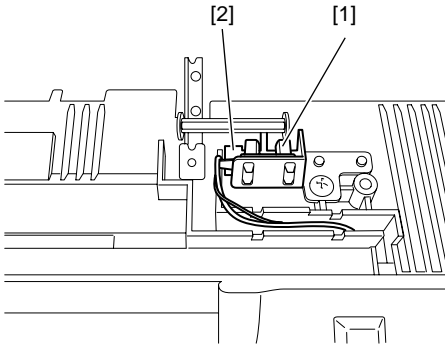

F-3-61

### 3.5.3.7 Removing the Tray B Paper Width Sensor

- 1) Detach the rear cover.
  - 2) Increase the top cover open/close angle.
  - 3) Detach the front cover.
  - 4) Remove the tray A unit.
  - 5) Remove the tray B unit.
  - 6) Detach the tray bottom cover (small) [1].
- Screw [2] 2 pcs.
- 7) Detach the tray bottom cover (large) [3].
- Screw [4] 6 pcs.

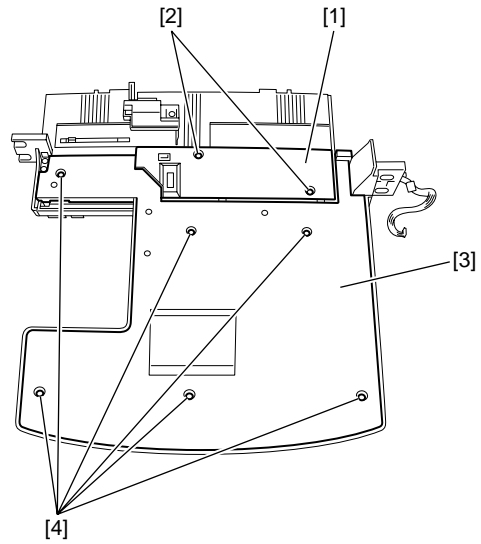

F-3-62

- 8) Remove the tray B paper width sensor [1].
- Screw [2] 2 pcs.  
- Screw [3] 1 pc.

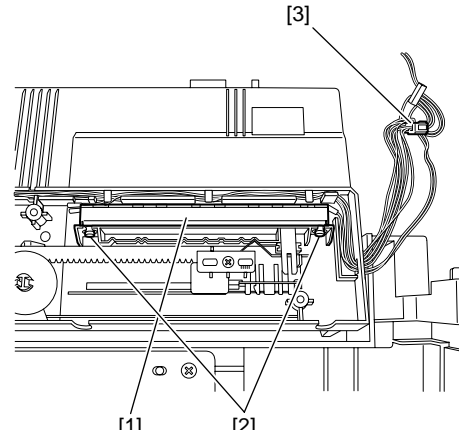

F-3-63



After replacing with the tray B paper width sensor with a new one, adjust the sensor output value in the service mode.

### 3.5.3.8 Removing the Tray B Paper Sensor 1

- 1) Detach the rear cover.
  - 2) Increase the top cover open/close angle.
  - 3) Detach the front cover.
  - 4) Remove the tray A unit.
  - 5) Remove the tray B unit.
  - 6) Detach the tray bottom cover (small) [1].
- Screw [2] 2 pcs.

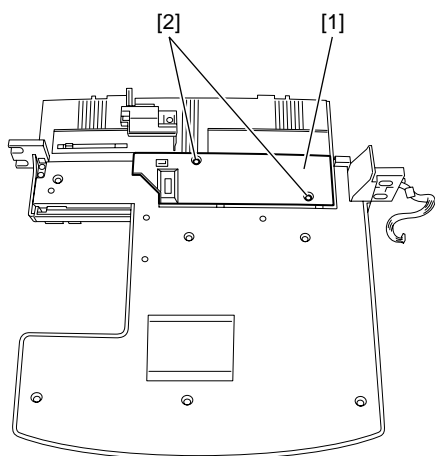

F-3-64

- 7) Remove the tray B paper sensor [1].  
- Connector [2] 1 pc.

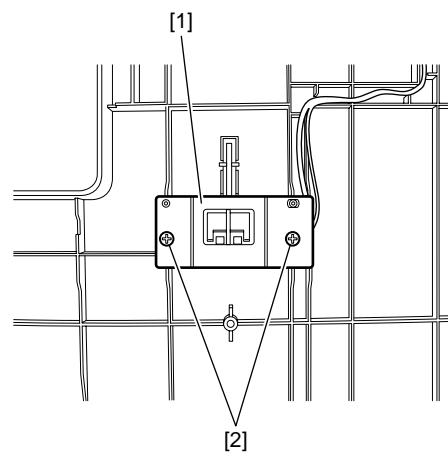

F-3-67

- 8) Remove the tray B paper sensor 2 [1].  
- Connector [2] 1 pc.

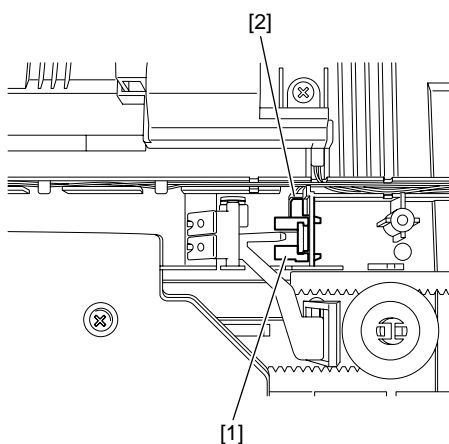

F-3-65

### 3.5.3.9 Removing the Tray B Paper Sensor 2

- 1) Detach the rear cover.
  - 2) Increase the top cover open/close angle.
  - 3) Remove the front cover.
  - 4) Remove the tray A unit.
  - 5) Remove the tray B unit.
  - 6) Detach the tray bottom cover (large) [1].
- Screw [2] 6 pcs.

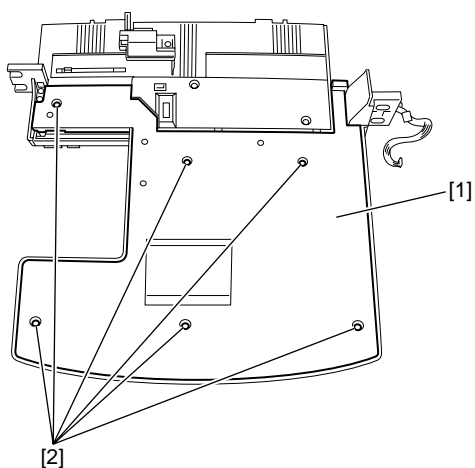

F-3-66

- 7) Remove the sensor unit [1].  
- Screw [2] 2 pcs.

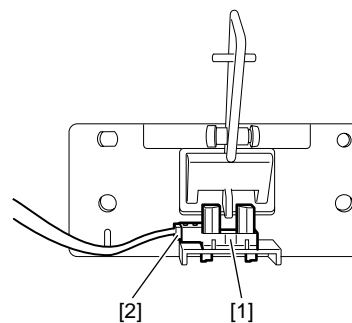

F-3-68

### 3.5.3.10 Removing the Tray B Pickup Sensor

- 1) Detach the rear cover.
  - 2) Increase the top cover open/close angle.
  - 3) Increase the middle cover open/close angle.
  - 4) Remove the guide [1].
- Screw [2] 2pcs.

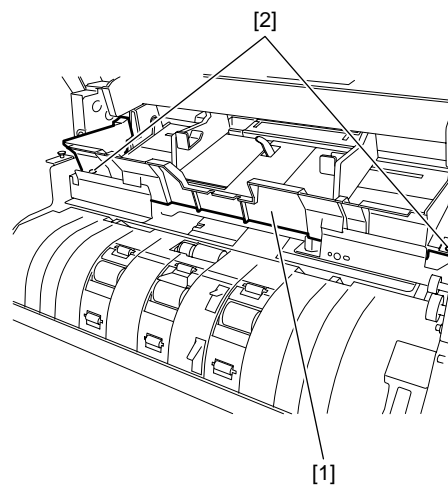

F-3-69

- 5) Remove the tray B sensor unit [1].
- Screw [2] 1 pc.
- 6) Remove the tray B pickup sensor [3].
- Connector [4]

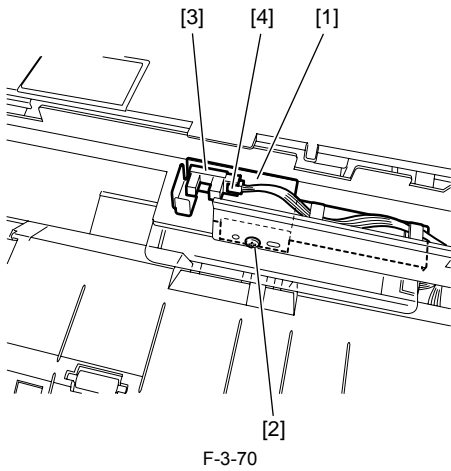

F-3-70

### 3.5.3.11 Removing the Tray A Lower Limit Sensor

- 1) Detach the rear cover.
  - 2) Increase the top cover open/close angle.
  - 3) Remove the front cover.
  - 4) Remove the tray A unit.
  - 5) Remove the tray B unit.
  - 6) Remove the tray A lower limit sensor [1].
- Connector [2] 1 pc.

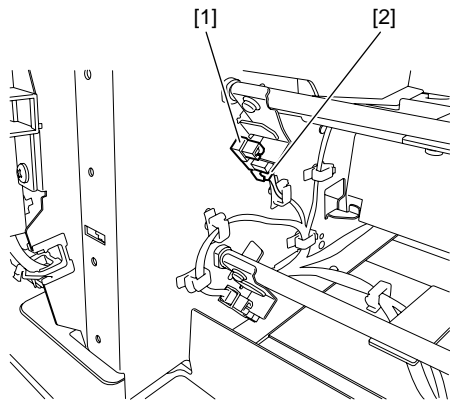

F-3-71

### 3.5.3.12 Removing the Tray B Lower Limit Sensor

- 1) Detach the rear cover.
  - 2) Increase the top cover open/close angle.
  - 3) Remove the front cover.
  - 4) Remove the tray A unit.
  - 5) Remove the tray B unit.
  - 6) Remove the tray B lower limit sensor [1].
- Connector [2] 1 pc.

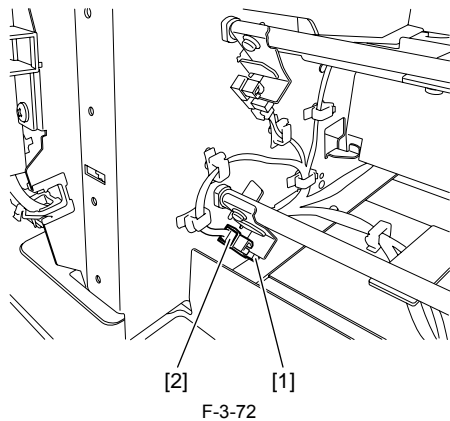

F-3-72

### 3.5.3.13 Removing the Tray B Registration Sensor

- 1) Detach the rear cover.
  - 2) Increase the top cover open/close angle.
  - 3) Increase the middle cover open/close angle.
  - 4) Remove the feed guide [1].
- Screw [2] 5 pcs.

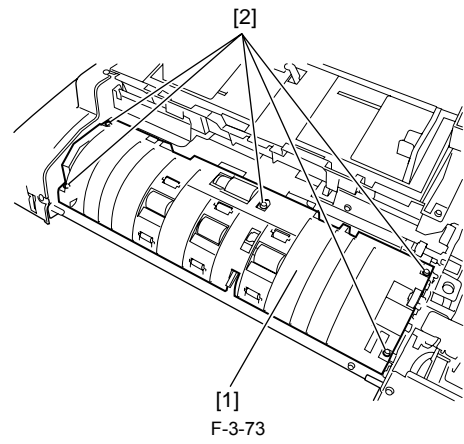

F-3-73

- 5) Remove the sensor unit [1].
- Screw [2] 1 pc.  
- Connector [3] 1 pc.

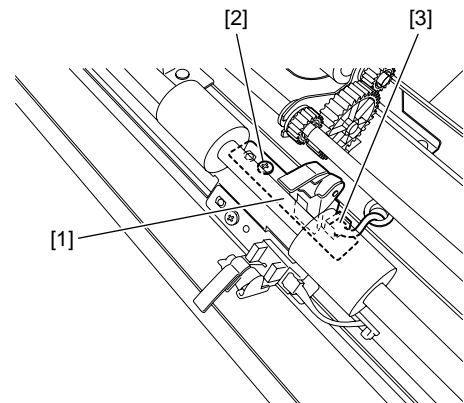

F-3-74

- 6) Remove the tray B registration sensor [1].

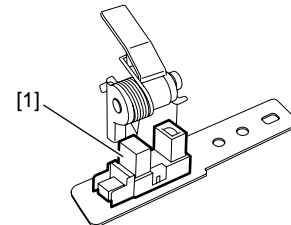

F-3-75

### 3.5.3.14 Removing the Feed Sensor

- 1) Detach the rear cover.
  - 2) Increase the top cover open/close angle.
  - 3) Increase the middle cover open/close angle.
  - 4) Remove the feed guide [1].
- Screw [2] 5 pcs.

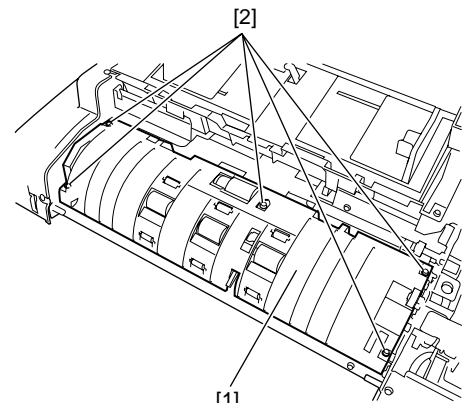

F-3-76

- 5) Remove the sensor unit [1].
- Screw [2] 1 pc.



- Connector [3] 1 pc.

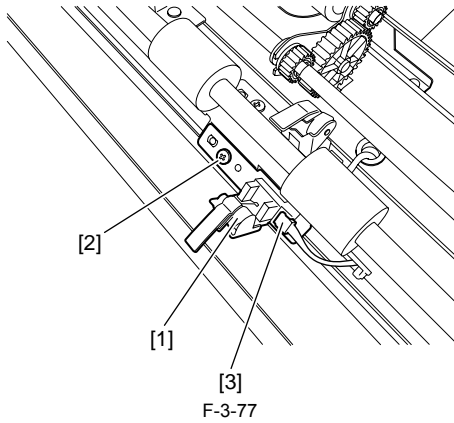

6) Remove the feed sensor [1].

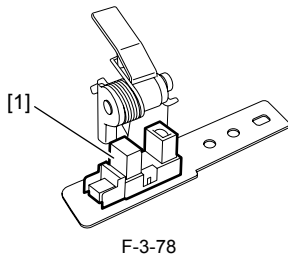

**3.5.3.15 Remove the Inserter Open/Close Sensor**

- 1) Detach the rear cover.
- 2) Remove the inserter open/close sensor [1].
- Connector [2] 1 pc.

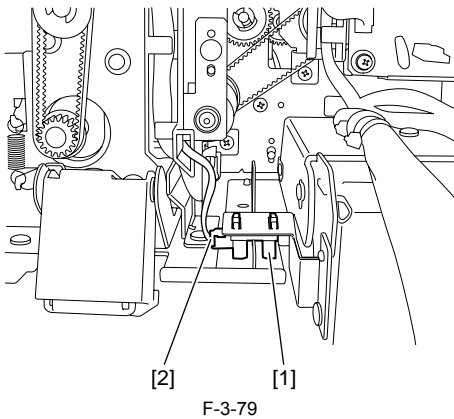

**3.5.3.16 Removing the Drive Switchover Sensor**

- 1) Detach the rear cover.
- 2) Remove the drive switchover sensor [1].
- Connector [2] 1 pc.

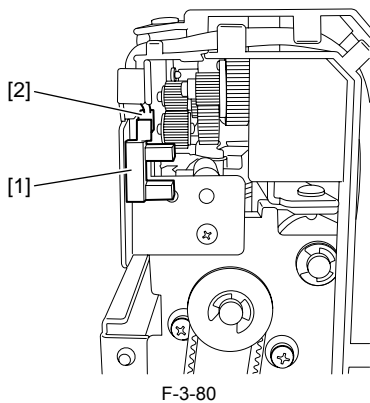

**3.5.3.17 Removing the Top Cover Open/Close Switch**

- 1) Detach the rear cover.

- 2) Increase the top cover open/close angle.
- 3) Detach the front cover.
- 4) Remove the top cover open/close switch [1].
- Faston terminal [2] 1 pc.
- Screw [3] 1 pc.

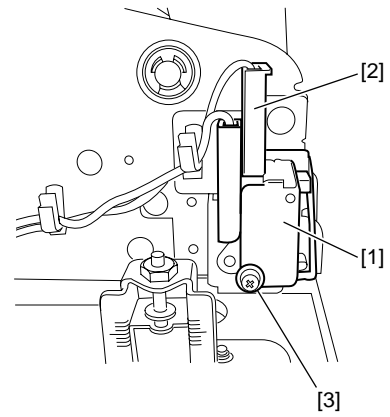

**3.5.3.18 Removing the Feed Sensor 2**

- 1) Remove the transfer unit.
- 2) Remove the cover plate [1].
- Screw [2] 4 pcs.

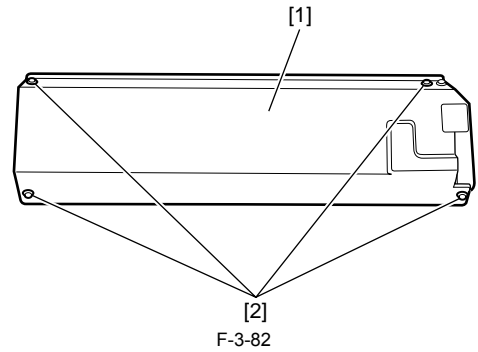

- 3) Remove the feed sensor 2 [1].
- Connector [2] 1 pc.

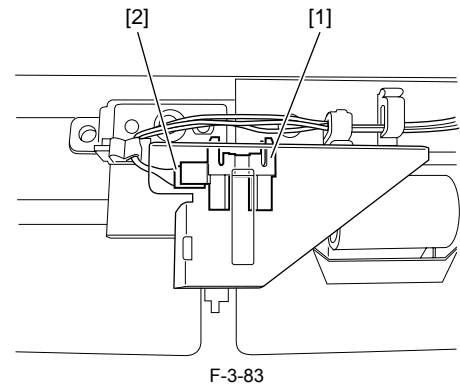



---

## Chapter 4 Maintenance

---



---

# Contents

4.1 Maintenance and Inspection.....	4-1
4.1.1 Periodically Replaced Parts.....	4-1
4.1.1.1 Periodically Replace Parts.....	4-1
4.1.2 Durables.....	4-1
4.1.2.1 Durables.....	4-1
4.1.3 Periodical Servicing.....	4-2
4.1.3.1 Scheduled Servicing.....	4-2
4.2 Adjustment.....	4-3
4.2.1 Basic Adjustment.....	4-3
4.2.1.1 Overview.....	4-3
4.2.1.2 Adjusting the inserter open/close.....	4-3
4.2.1.3 Adjusting the Height.....	4-3
4.2.1.4 Adjusting the Document Tray Width.....	4-4
4.2.1.5 Adjusting the Upper Cover Positioning Pin.....	4-4
4.3 Outline of Electrical Components.....	4-6
4.3.1 Sensors.....	4-6
4.3.2 Motor/ Clutch/ PCB.....	4-7
4.4 Variable Resistors (VR), Light-Emitting Diodes (LED), and Check Pins by PCB.....	4-8
4.4.1 Inserter Controller PCB.....	4-8
4.4.2 Explanation of DIP Switch Functions.....	4-8
4.5 Upgrading.....	4-11
4.5.1 Upgrading (Inserter Unit).....	4-11



## 4.1 Maintenance and Inspection

### 4.1.1 Periodically Replaced Parts

#### 4.1.1.1 Periodically Replace Parts

The machine does not have parts that must be replaced on a periodical basis.

### 4.1.2 Durables

#### 4.1.2.1 Durables

Some parts of the machine may have to be replaced once or more over the period of product warranty. Replace them when they fail.

T-4-1

					as of Nonember 2005
No.	Parts name	Parts No.	Q'ty	Estimated life	Remarks
1	Pickup roller	4A3-3870	4	100,000 sheets	
2	Separation roller	4A3-3868	2	100,000 sheets	
3	Feed roller	4A3-3869	2	100,000 sheets	
4	Torque limiter	4A3-3888	2	1,000,000 sheets	

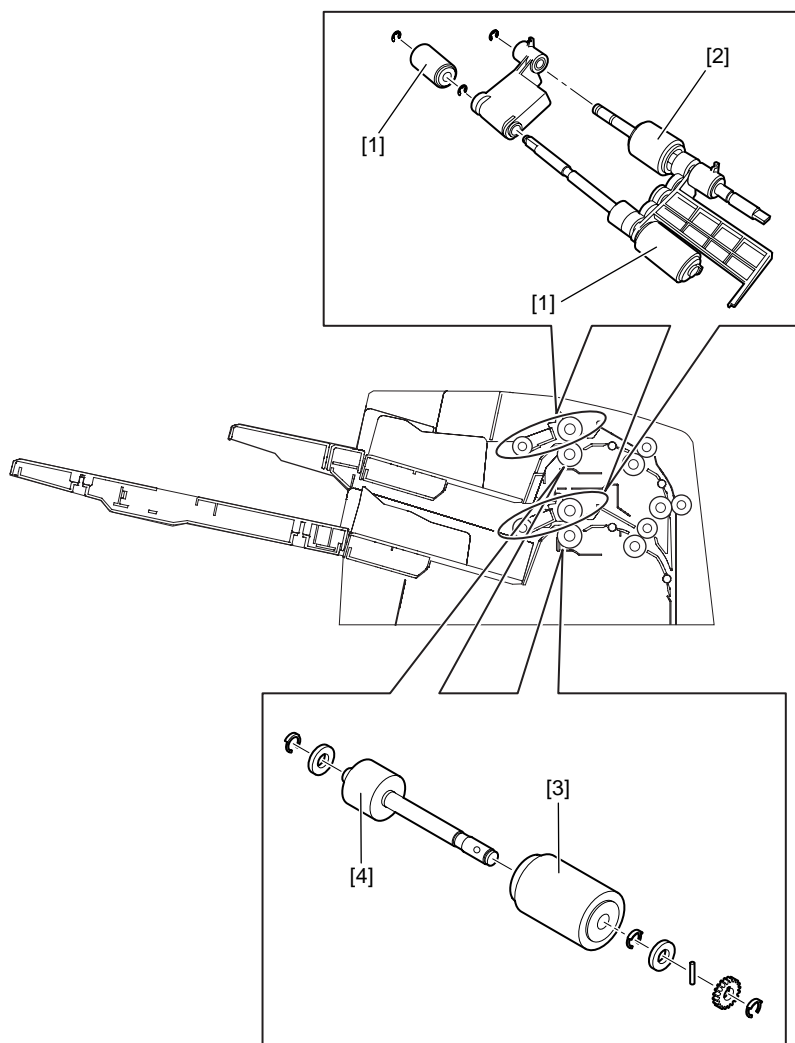

F-4-1



The life of a part indicated here is a median value from evaluation data. The parts No. in the table is subject to change (e.g., change in design).

### 4.1.3 Periodical Servicing

#### 4.1.3.1 Scheduled Servicing

T-4-2

No	Parts name	Scheduled service			Remarks
		50,000	100,000	1,000,000	
1	Pickup roller	clean	raplace		Clean it with a cloth dampened with water or neutral detergent and squeezed hard, and then wipe it with a dry soft cloth.
2	Feed roller	clean	raplace		
3	Separation roller	clean	raplace		
4	Torque limiter			raplace	

 The foregoing values are estimates only, and are subject to change based on future data.



## 4.2 Adjustment

### 4.2.1 Basic Adjustment

#### 4.2.1.1 Overview

Adjustment items of this machine are as follows:

1. Inserter open/close adjustment (when the inserter is installed)
2. Inserter height adjustment (when the inserter is installed)
3. Document tray width adjustment (when the document width sensor is replaced)
4. Top cover positioning pin adjustment (when the top cover is replaced)

#### 4.2.1.2 Adjusting the inserter open/close

##### 1. Pre-check

Close the inserter and check whether the positioning pin [1] on the finisher fits in the hole [2] on the bottom of the inserter. (The check result is OK when the inserter closes by its own weight even if the positioning pin does not enter the hole smoothly.)

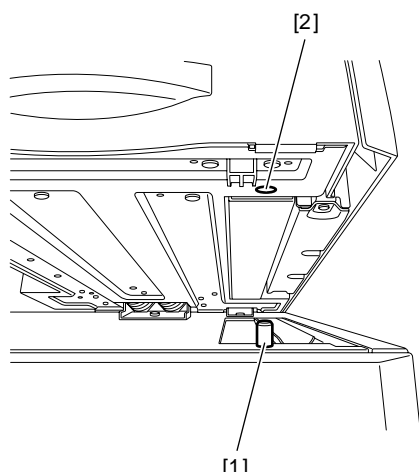

F-4-2

If the positioning pin does not enter the hole, adjust the inserter position by adjusting the position of the hinge's adjusting plate following the procedure below.

<Adjustment Procedure>

1. Open the inserter and loosen the two screws (M4) fastened to secure the hinge in step 4).
2. Loosen the hex nut [1] and turn the adjusting screw [2] using a hex wrench. Adjust the inserter position with reference to the marks [3] on the front plate. Moving the plate by one gradation (1 mm) moves the front side of the inserter 4.6 mm to the left/right.
  - Turning the adjusting screw clockwise moves the plate forward and moves the inserter to the left.
  - Turning the adjusting screw counterclockwise moves the plate backward and moves the inserter to the right.
3. Tighten the two screws (M4) to secure the hinge.
4. Repeat steps 1-3 until the positioning pin fits in the hole.

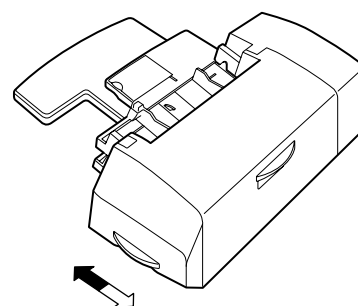
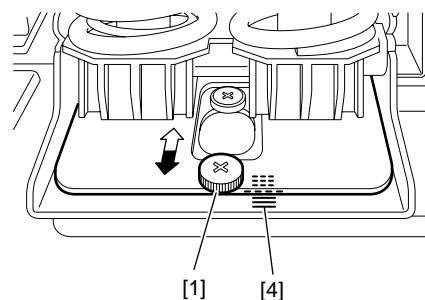
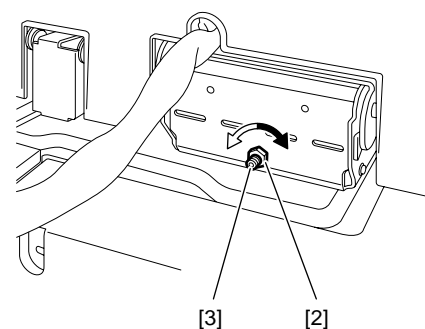

F-4-3

#### 4.2.1.3 Adjusting the Height

##### 1. Pre-check

Check whether the difference in clearance (between the right side of the inserter and the finisher) between the front end (A) and rear end (B) is within 1 mm.

If it is not within 1 mm, adjust the eight following the procedure below.

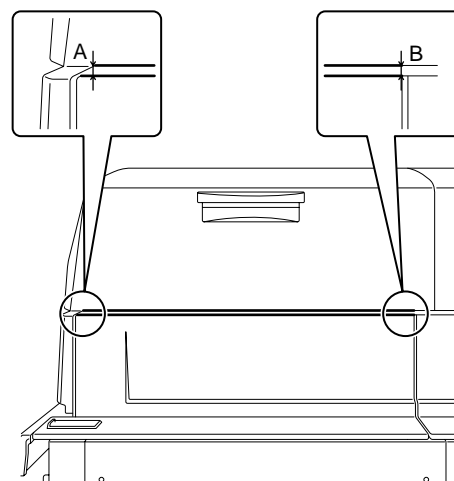

F-4-4

<Adjustment Procedure>

- 1) Remove the rear cover.
- 2) Increase the top cover open/close angle.
- 3) Detach the front cover.
- 4) Loosen the screw [1] and hex nut [2] on the right-side height adjusting mechanism.
- 5) Using a hex wrench, turn the adjusting screw [3] to adjust the difference in clearance (between the right side of the inserter and the finisher) between the front end and rear end to within 1 mm. Turning the adjusting screw by one gradation (1 mm) moves the inserter 1 mm.
  - Turning the adjusting screw clockwise moves the inserter up.
  - Turning the adjusting screw counterclockwise moves the inserter down.

6) Tighten the screw [1] and hex nut [2].

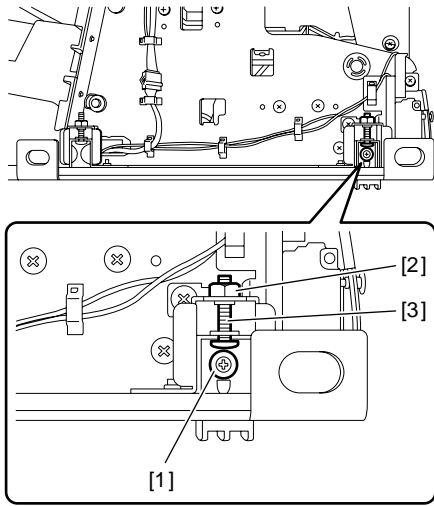

F-4-5

- 7) Adjust the height of the left-side height adjusting mechanism to the same mark as that of the right-side height adjusting mechanism. Follow the same procedure as in step 5.
- 8) After completion of adjustment, reinstall the removed parts.

#### 4.2.1.4 Adjusting the Document Tray Width

- 1) Set the following paper on the tray to be adjusted and adjust the width of the slide guide to that of the paper.
  - A/B type: A4
  - Inch type: LTR
- 2) Detach the rear cover, set bit 1 of the DIP switch (SW1) to ON, and turn on the power.

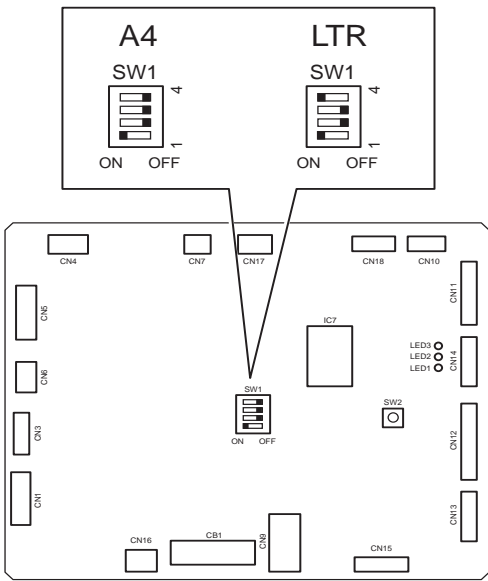

F-4-6

- 3) Check that the LED1 lights.
- 4) Set bit 1 of the DIP switch (SW1) to ON and press the push switch (SW2).
- 5) After completion of A4 or LTR adjustment, check that LED2 lights.
- 6) Adjust the width of the slide guide to the width of the following paper:
  - A/B type: A4R
  - Inch type: LTRR
- 7) Press the push switch (SW2).
- 8) After completion of A4 or LTR adjustment, check that LED1 blinks.
- 9) Set all bits of the DIP switch (SW1) to OFF.
- 1) Remove the rear cover.
- 2) Set the DIP switch (SW1) as follows to suit the paper size series in question, and turn on the power.

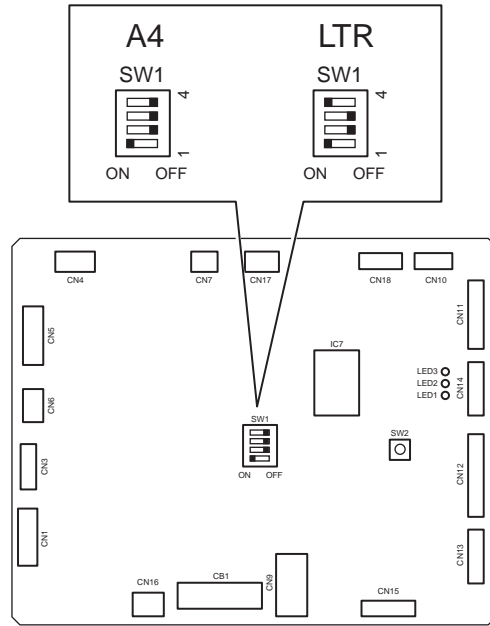

F-4-7

- 3) Set the DIP switch (SW1) as follows to suit the tray in question, and press the push switch (SW2):

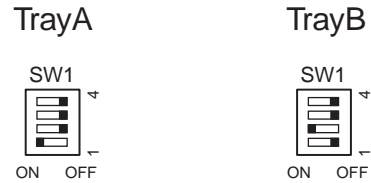

F-4-8

- 4) Check to see that LED1 is on.
- 5) Adjust the slide guide to the following width (minimum width adjustment):
  - if A/B size series, A4R
  - if inch size series, LTRR
- 6) Press the push switch (SW2).
- 7) When done, see that LED2 goes on.
- 8) Adjust the slide guide to the following width (maximum width adjustment):
  - if A/B size series, A4
  - if inch size series, LTR
- 9) When done, see that all LEDs are off (to end adjustment).
- 10) Shift all bits of the DIP switch (SW1) to OFF.

#### 4.2.1.5 Adjusting the Upper Cover Positioning Pin

1. Before Starting the Work  
After replacing the upper cover or the upper cover unit, adjust the positioning pin as follows if the upper cover fails to lock or resist locking when the inserter upper cover is closed:

##### <Making Adjustments>

- 1) Remove the rear cover.
- 2) Increase the open/close angle of the upper cover.
- 3) Loosen the 2 screws [1] and the other screw [2].
- 4) Twist the upper cover lightly, and move the adjusting plate by referring to the margin [3]; then, fix it in place by the screw [2].
  - Moving the marking [3] toward the front will move the positioning pin [4] toward the front.
  - Moving the marking [3] toward the rear will move the positioning pin [4] toward the rear.
- 5) Close the top cover to see that it closes and opens smoothly. If it does not, go back to step 4).
- 6) Tighten the 2 screws [1] that have been tightened temporarily.

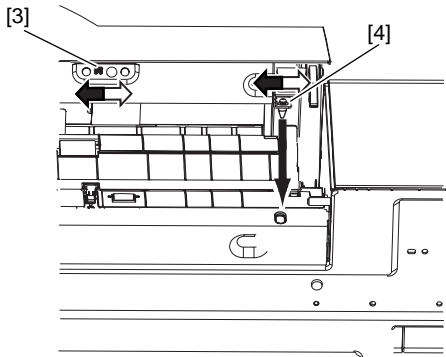
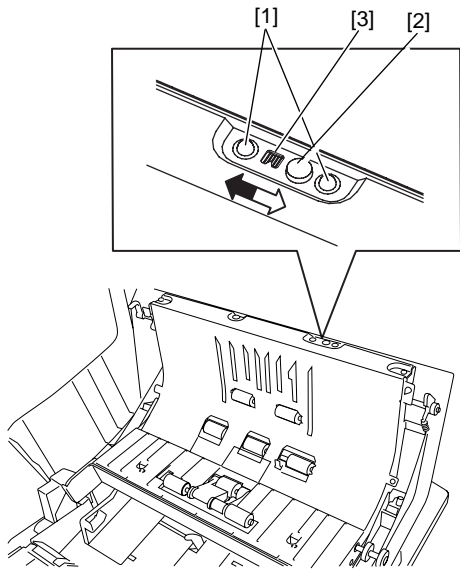

F-4-9

### 4.3 Outline of Electrical Components

#### 4.3.1 Sensors

T-4-3

Symbol	Name	Parts number	Inserter controller PCB	Jam code	Error code
S1	tray A paper set sensor	WG8-5696	CN14	0070	
S2	tray A paper width sensor	4H3-0282	CN14	0072	E515
S3	tray A paper sensor	WG8-5696	CN14	0031	
S4	tray A pickup sensor	WG8-5696	CN10		
S5	tray A registration sensor	WG8-5696	CN10	0062,0063,0074	
S6	tray B paper set sensor	WG8-5696	CN11	0071	
S7	tray B paper width sensor	4H3-0282	CN11	0072	E515
S8	tray B paper sensor 1	WG8-5696	CN11		
S9	tray B paper sensor 2	WG8-5696	CN11		
S10	tray B pickup sensor	WG8-5696	CN12		
S11	tray A lower limit sensor	WG8-5696	CN12		E515
S12	tray B lower limit sensor	WG8-5696	CN12		E515
S13	tray B registration sensor	WG8-5696	CN12	0064,0065,0074	
S14	feed sensor	WG8-5696	CN12	0066,0067,0074	
S15	inserter open/close sensor	WG8-5696	CN12		
S16	drive switchover sensor	WG8-5696	CN12		E515
S17	top cover open/close sensor	4H1-6449	CN16	0075	
S18	feed sensor 2	WG8-5696	CN13	006A,006B,0074	

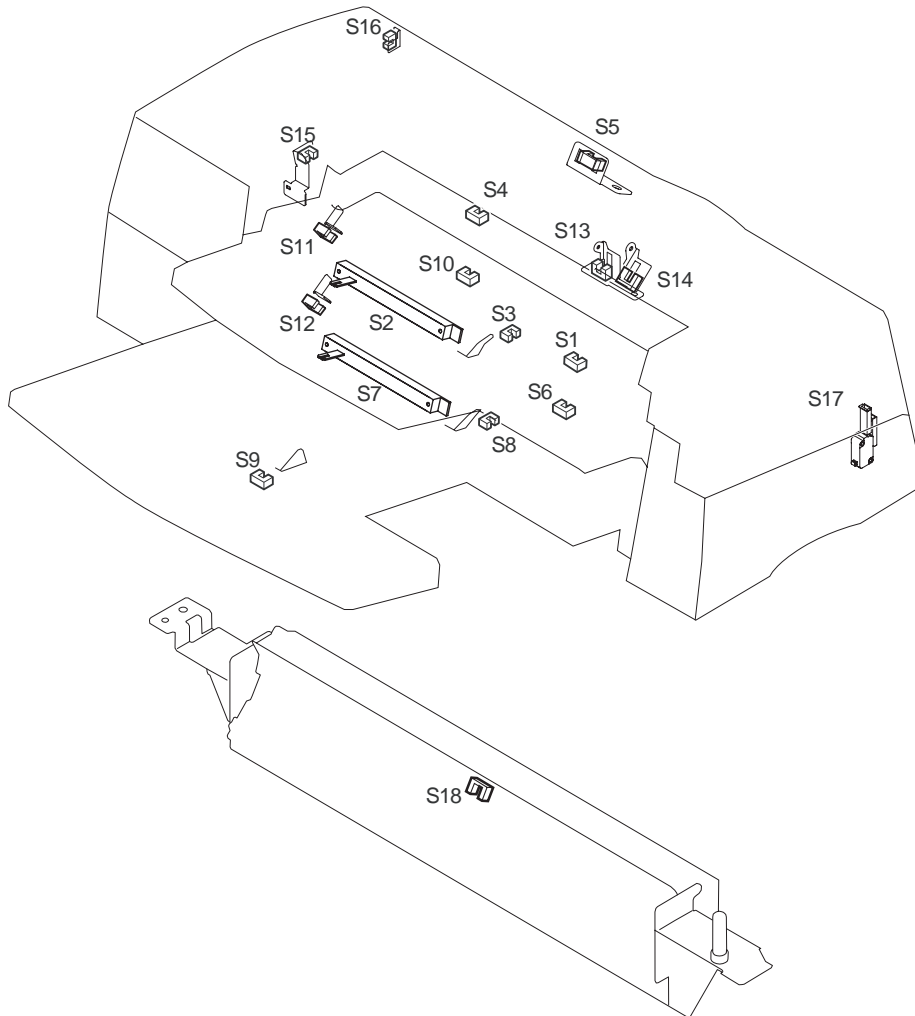

F-4-10

4.3.2 Motor/ Clutch/ PCB

T-4-4

Symbol	Name	Parts number	Inserter controller PCB	Error code
M1	tray pickup motor	4H3-0288	CN1	
M2	drive switchover motor	FH5-1041	CN6	E515
M3	tray A lift motor	FH5-1040	CN5	E515
M4	tray B lift motor	FH5-1040	CN5	E515
M6	feed motor	4H3-0292	CN3	
CL1	tray A thick paper registration clutch	4H3-0290	CN4	
CL2	tray B thick paper registration clutch	4H3-0290	CN4	
[1]	Inserter controller PCB	4H3-0267		
[2]	TrayA LED PCB	4G3-1713	CN17	
[3]	TrayB LED PCB	4G3-1713	CN17	

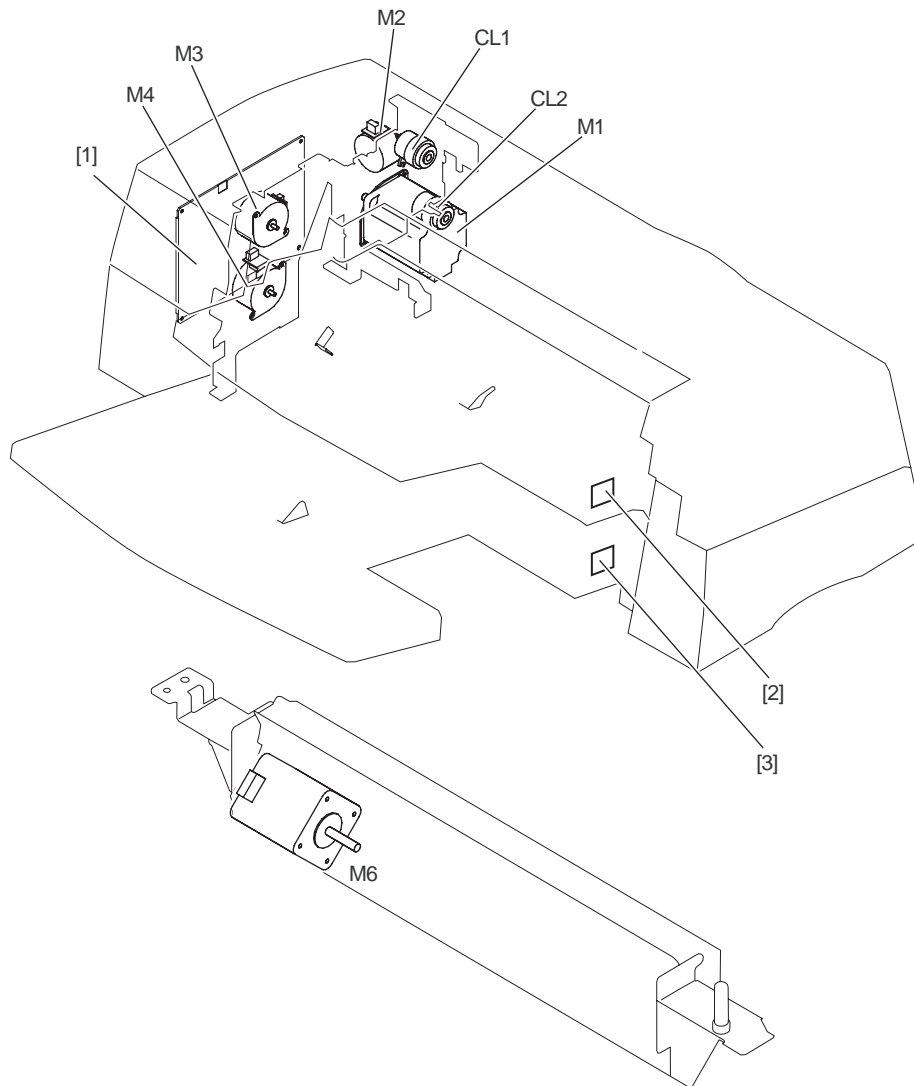

F-4-11

## 4.4 Variable Resistors (VR), Light-Emitting Diodes (LED), and Check Pins by PCB

### 4.4.1 Inserter Controller PCB

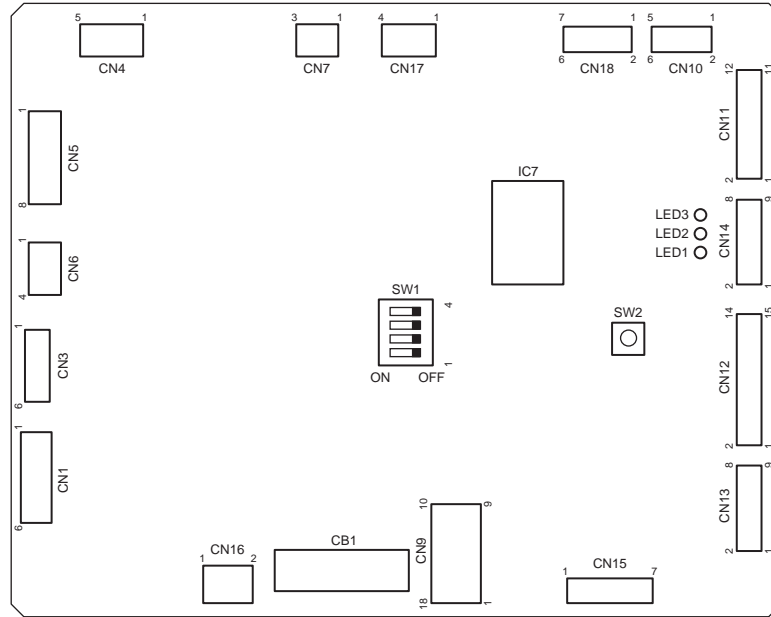

F-4-12

LED1 to LED3 are used to indicate the following statuses:

- 1. Normal status display
- Standby (Normal mode)
- Standby (Service mode)

Normal status display

In the standby status, LED1 to LED3 indicate the following statuses:

T-4-5

	On	Off	Blink
LED1	-	-	Standby status Normal: Blinks at intervals of 0.5 sec. Service mode: Blinks at intervals of 1 sec.
LED2	Top cover is open.	op cover is closed.	-
LED3	Inserter is open.	Inserter is closed.	-

2. Abnormal status display

- Jam
- Error

When a problem is detected in the inserter, LEDs indicate statuses a to d sequentially.

a. Occurrence of problem (jam or error)

All LEDs are held on for one second. -> All LEDs are held off for one second.

b. The cause of the problem is displayed.

LEDs are held on for one second. -> LEDs are held off for one second.

T-4-6

LED1	LED2	LED3	Description	When an error occurs
On	Off	Off	Delay jam	Tray A lift motor
Off	On	Off	Stationary jam	Tray B lift motor
On	On	Off	Power-on jam	Drive switchover motor
Off	Off	On	Error	EEPROM
On	Off	On	Cover open jam	Communication
Off	On	On	Paper size mismatch jam	Side regulating plate adjustment

c. Display of the jam detection sensor and error type

LEDs are held on for 0.5 second. -> LEDs are held off for 0.25 second.

T-4-7







LED1	LED2	LED3	When a jam occurs	When an error occurs
On	Off	Off	Tray A registration sensor	Tray A lift motor
Off	On	Off	Tray B registration sensor	Tray B lift motor
On	On	Off	Feed sensor	Drive switchover motor
Off	Off	On	-	EEPROM
On	Off	On	Feed sensor 2	Communication
Off	On	On	-	Side regulating plate adjustment











d. Status a is restored 0.75 second after all LEDs go off.

### 4.4.2 Explanation of DIP Switch Functions

This section explains functions of the DIP switches (SW1) on the inserter controller PCB.

By default, all DIP switch bits are set to OFF.

Item	DIP switch (SW1) setting at power-on	DIP switch (SW1) setting during execution of function	Description
Tray width adjustment mode	A4 adjustment SW1  ON OFF	SW1  ON OFF	Tray A width adjustment For the adjustment procedure to perform in the tray width adjustment mode, refer to Maintenance > Adjustment > Basic Adjustment > Adjusting the Document Tray Width.
	LTR adjustment SW1  ON OFF	SW1  ON OFF	Tray B width adjustment For the adjustment procedure to perform in the tray width adjustment mode, refer to Maintenance > Adjustment > Basic Adjustment > Adjusting the Document Tray Width.
Operation check mode	SW1  ON OFF	-	Check of individual operations of motors Each time the push switch (SW2) is pressed, drive motors run in the following order. Note that step 14 is followed by step 1. 1. The drive switchover motor starts. It stops when the tray A pickup side is reached. 2. The pickup motor starts (tray A pickup, 250 mm/s). It stops when the push switch (SW2) is pressed. 3. The pickup motor starts (tray A pickup, 500 mm/s). It stops when the push switch (SW2) is pressed. 4. The pickup motor starts (tray A feed, 1100 mm/s). It stops when the push switch (SW2) is pressed. 5. The drive switchover motor starts. It stops when the tray B pickup side is reached. 6. The pickup motor starts (tray B pickup, 250 mm/s). It stops when the push switch (SW2) is pressed. 7. The pickup motor starts (tray B pickup, 500 mm/s). It stops when the push switch (SW2) is pressed. 8. The pickup motor starts (tray B feed, 1100 mm/s). It stops when the push switch (SW2) is pressed. 9. The feed motor (feed, 1100 mm/s) stops when the push switch (SW2) is pressed. 10. The tray A lift motor starts. It stops when tray A has been lifted up. 11. The tray A lift motor starts. It stops when tray A has been lifted down. 12. The tray B lift motor starts. It stops when tray A has been lifted up. 13. The tray B lift motor starts. It stops when tray B has been lifted down. 14. The tray A/B registration clutch starts. It stops 500 ms later.
	SW1  ON OFF	-	Check of motor operation sequence After the power is turned on, the following operations are performed in sequence. When the operation sequence is complete, turn off the power. Pressing the push switch (SW2) stops the sequence. Pressing the push switch (SW2) again restarts the sequence from step 1. 1. Tray A is pre-lifted up. 2. 50 sheets are supplied. 3. Tray A is lifted down. 4. Tray B is pre-lifted up. 5. 50 sheets are supplied. 6. Tray B is lifted down. Steps 1 to 6 are repeated. The separation speed and feed speed are selected as follows: Odd-numbered feed: Separation speed = 50 mm/s Feed speed = 1100 mm/s Even-numbered feed: Separation speed = 250 mm/s Feed speed = 325 mm/s

Item	DIP switch (SW1) setting at power-on	DIP switch (SW1) setting during execution of function	Description
Sensor check mode			<p>Sensor check mode 1</p> <p>Setting the DIP switch (SW1) and pressing the push switch (SW2) allows you to assign sensors to LEDs.</p> <ul style="list-style-type: none"> <li>- Each LED goes on when presence of paper or opening of cover is detected.</li> <li>- Each LED goes out when absence of paper or closing of cover is detected.</li> <li>- LED1: Tray A paper set sensor</li> <li>- LED2: Tray A pickup sensor</li> <li>- LED3: Tray A registration sensor</li> </ul>
			<p>Sensor check mode 2</p> <p>Setting the DIP switch (SW1) and pressing the push switch (SW2) allows you to assign sensors to LEDs.</p> <ul style="list-style-type: none"> <li>- Each LED goes on when presence of paper or opening of cover is detected.</li> <li>- Each LED goes out when absence of paper or closing of cover is detected.</li> <li>- LED1: Tray A paper sensor</li> <li>- LED2: Tray B paper sensor 1</li> <li>- LED3: Tray B paper sensor 2</li> </ul>
			<p>Sensor check mode 3</p> <p>Setting the DIP switch (SW1) and pressing the push switch (SW2) allows you to assign sensors to LEDs.</p> <ul style="list-style-type: none"> <li>- Each LED goes on when presence of paper or opening of cover is detected.</li> <li>- Each LED goes out when absence of paper or closing of cover is detected.</li> <li>- LED1: Tray B paper set sensor</li> <li>- LED2: Tray B pickup sensor</li> <li>- LED3: Tray B registration sensor</li> </ul>
			<p>Sensor check mode 4</p> <p>Setting the DIP switch (SW1) and pressing the push switch (SW2) allows you to assign sensors to LEDs.</p> <ul style="list-style-type: none"> <li>- Each LED goes on when presence of paper or opening of cover is detected.</li> <li>- Each LED goes out when absence of paper or closing of cover is detected.</li> <li>- LED1: Feed sensor</li> <li>- LED2: Unused</li> <li>- LED3: Feed sensor 2</li> </ul>
			<p>Sensor check mode 5</p> <p>Setting the DIP switch (SW1) and pressing the push switch (SW2) allows you to assign sensors to LEDs.</p> <ul style="list-style-type: none"> <li>- Each LED goes on when presence of paper or opening of cover is detected.</li> <li>- Each LED goes out when absence of paper or closing of cover is detected.</li> <li>- LED1: Tray A lower limit sensor</li> <li>- LED2: Tray B lower limit sensor</li> <li>- LED3: Drive switchover sensor</li> </ul>
			<p>Sensor check mode 6</p> <p>Setting the DIP switch (SW1) and pressing the push switch (SW2) allows you to assign sensors to LEDs.</p> <ul style="list-style-type: none"> <li>- Each LED goes on when presence of paper or opening of cover is detected.</li> <li>- Each LED goes out when absence of paper or closing of cover is detected.</li> <li>- LED1: Unused</li> <li>- LED2: Top cover open/close switch</li> <li>- LED3: Inserter open/close sensor</li> </ul>
Offline mode			<p>Pickup operation 1 (Separation speed = 500 mm/s)</p> <p>Since the purpose of this test is to check the pickup operation of the inserter, the inserter must be disconnected from the host machine in advance.</p> <ol style="list-style-type: none"> <li>1. Set paper in each tray, and then press the push switch (SW2).</li> </ol> <p>With paper present in both trays A and B, perform the pickup operation starting with tray A.</p> <ol style="list-style-type: none"> <li>2. The pickup operation stops when absence of paper is detected in both trays or the push switch (SW2) is pressed.</li> </ol>
			<p>Pickup operation 2 (Separation speed = 250 mm/s)</p> <p>Since the purpose of this test is to check the pickup operation of the inserter, the inserter must be disconnected from the host machine in advance.</p> <ol style="list-style-type: none"> <li>1. Set paper in each tray, and then press the push switch (SW2).</li> </ol> <p>With paper present in both trays A and B, perform the pickup operation starting with tray A.</p> <ol style="list-style-type: none"> <li>2. The pickup operation stops when absence of paper is detected in both trays or the push switch (SW2) is pressed.</li> </ol>
Pickup retry mode			<p>Addition of retry time to pickup processing time</p> <p>In this mode, the pickup processing time is set assuming that pickup is retried twice and the set time is reported to the host machine.</p> <p>Use of this mode reduces the productivity of the inserter.</p>



## 4.5 Upgrading

### 4.5.1 Upgrading (Inserter Unit)

#### - Outline

The flash ROM is built-in with IC7 (CPU) of the inserter unit. downloader PCB (FY9-2034) is required to upgrade IC1. Refer to below for how to use the downloader PCB (FY9-2034).

#### - How to use the downloader PCB (FY9-2034)

##### 1.Purpose

To use when upgrading the version of the CPU (IC7) of the inserter controller PCB.

##### 2.Components of the downloader PCB

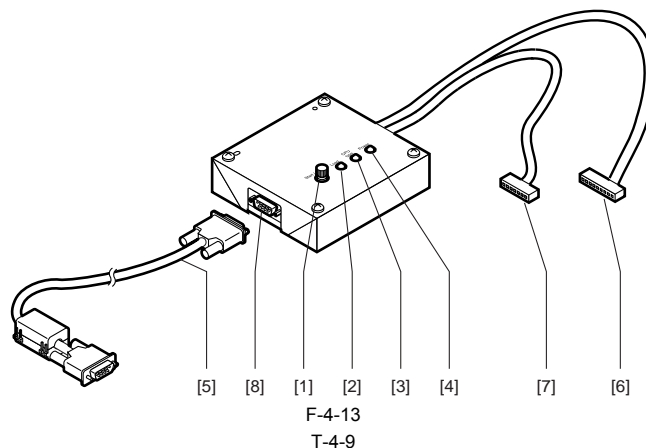

No.	Description	Function
[1]	START/STOP key	A key to be pressed when you start or stop download
[2]	LOAD LED	To be lit when download is available.
[3]	Model LED	To be lit when the Finisher is connected.
[4]	Power LED	To be lit when power is supplied from the Finisher to the downloader PCB
[5]	RS-232C cable (straight full wiring; 9 pins)	A cable to connect the downloader PCB and a PC. Be sure to connect the cable in a way that its ferrite core comes to the PC side.
[6]	Cable A (9 pins) Length: approx. 70cm	A cable to connect the downloader PCB and other products
[7]	Cable B (7 pins) Length: approx. 50cm	A cable to connect the downloader PCB and the Finisher
[8]	RS-232C connector	A connector to connect an RS-232C cable to the downloader PCB

#### 3.Tool

The following tool is required to perform download work.

##### - PC

Condition: The download tool (Ver.3.21E or later) must be downloaded.

#### 4.Download procedure

##### a. Addition of ROM data

- 1) Add the ROM data to be downloaded to the folder C: \ ServTool \ NewROM
- 2) Start up the Service Support Tool.  
C: \ ProgramFiles \ Service Support Tool \ bpchost.exe
- 3) Select [Register System Software].

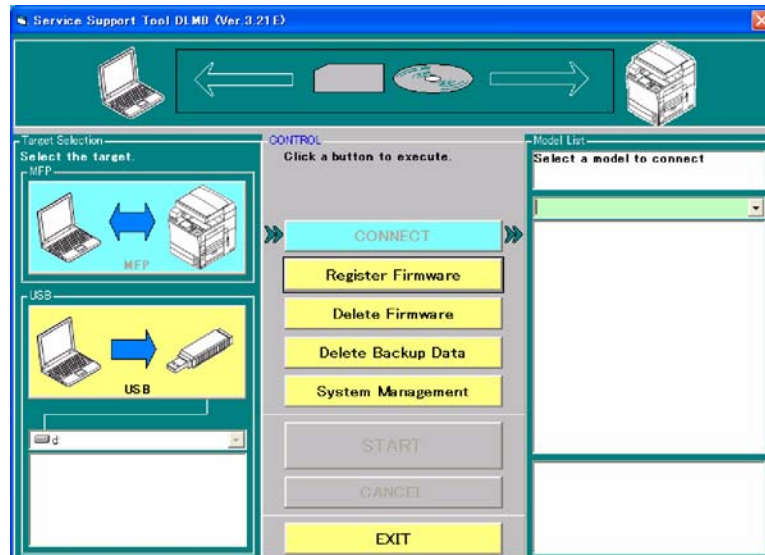

F-4-14

4) Select the data in the NewROM folder.

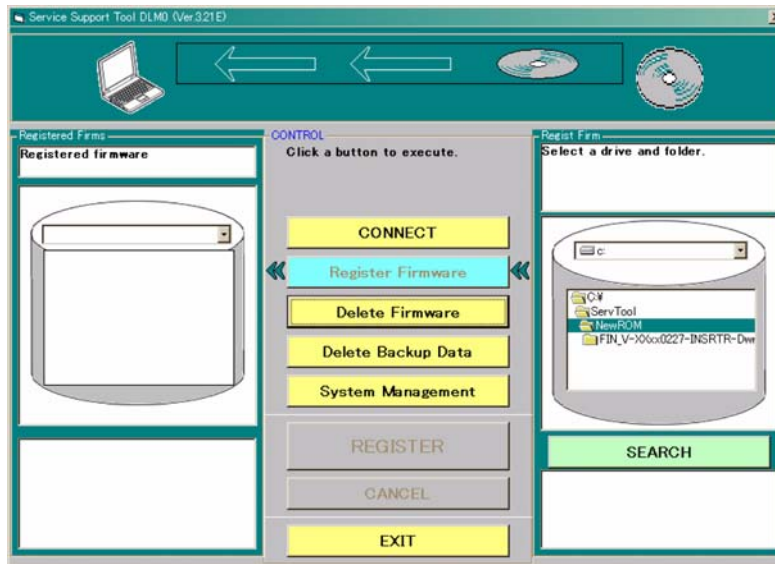

F-4-15

5) Press the [Register] button.

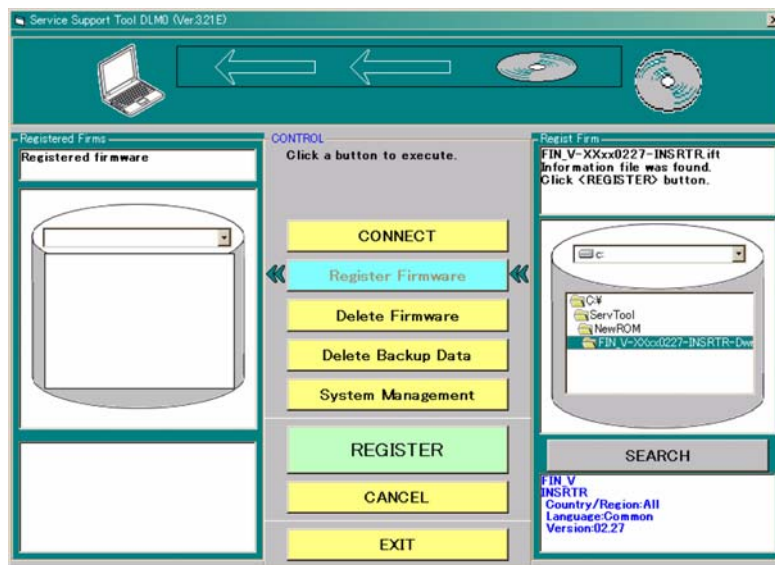

F-4-16

6) Press the [OK] button to register the data.

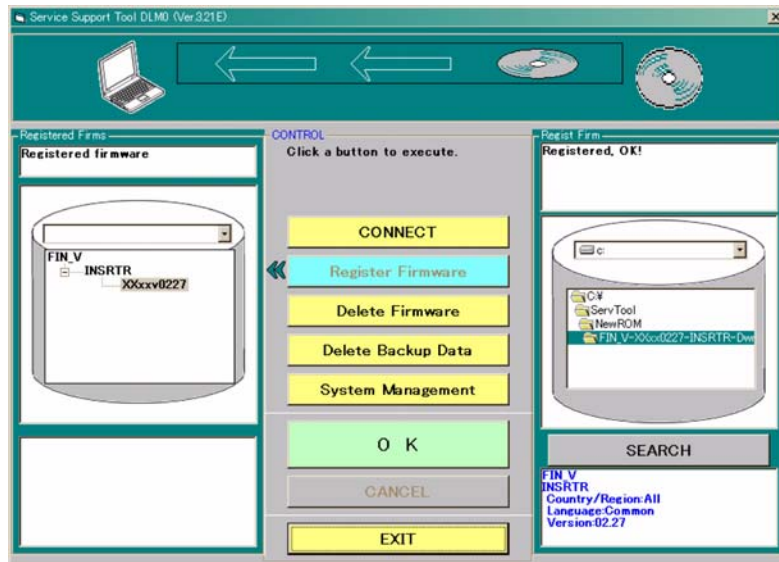

F-4-17

## b. Connection to the finisher

- 1) Turn OFF the machine.
- 2) Remove the machine rear cover
- 3) Connect the cable B to CN15 on the inserter controller PCB.
- 4) Connect the RS-232C cable to the PCB and the RS-232C connector of the PC.  
Make sure at this time that the ferrite core of the RS-232C cable comes to the PC side.
- 5) Turn ON the machine.

## c. Download

- 1) Start up the Service Support Tool.  
C:\ProgramFiles\Service Supprt Tool\bpchost.exe
- 2) Select a model to be connected.

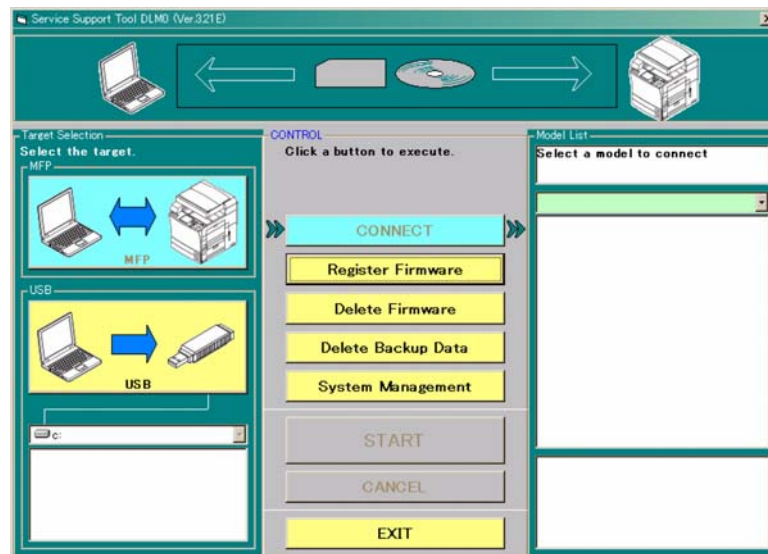

F-4-18

- 3) Press the [START/STOP] key.  
The LOAD LED will light up.
- 4) Select the 'INSRTR'.  
Highlight the model name, and press the [Connect] key.

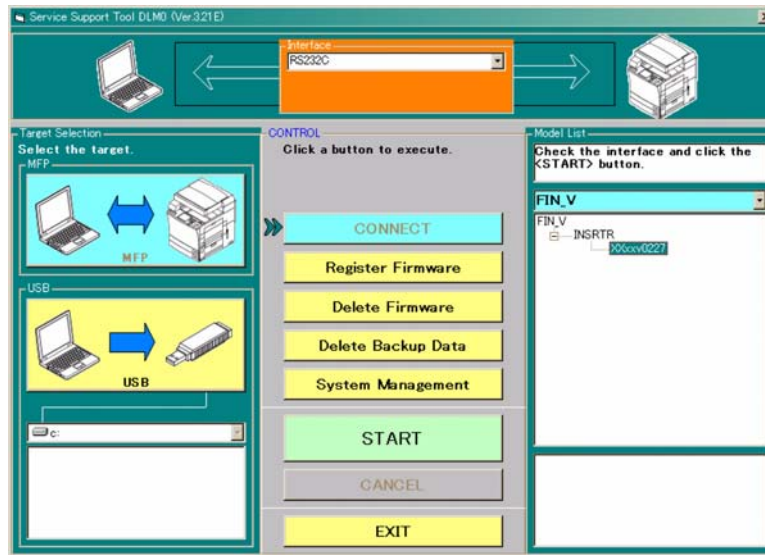

F-4-19

5) Follow the screens to check preparations for download. The next screen appears with a press of the [OK] key on the screen.

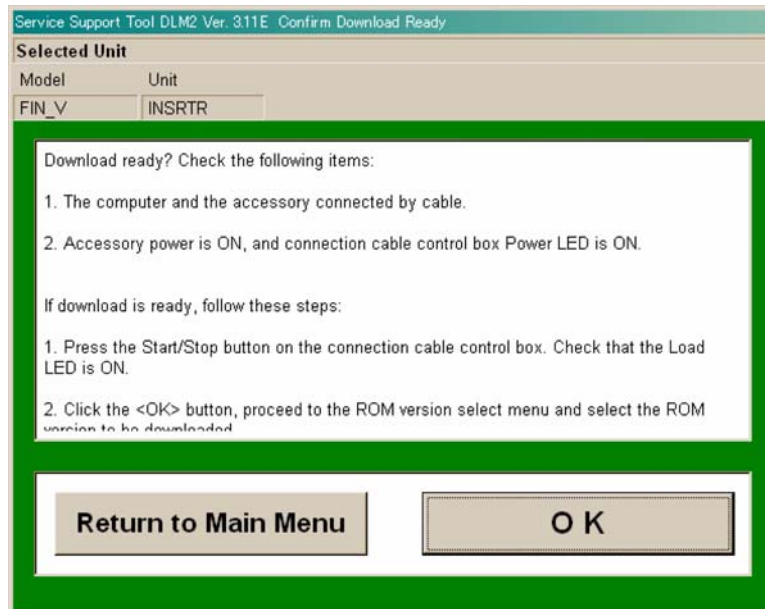

F-4-20

6) Select the ROM version to be downloaded.

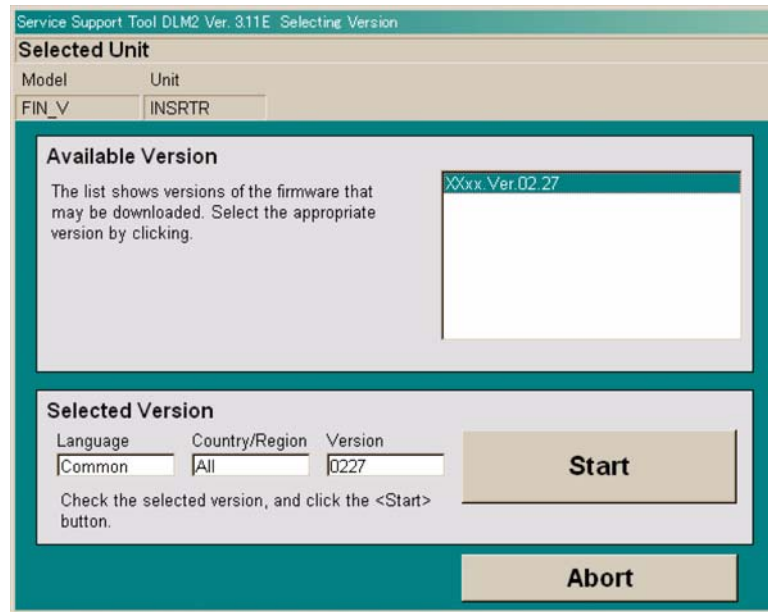

F-4-21

7) The PC and the downloader PCB will start to download the program with a press of the [Start] key.

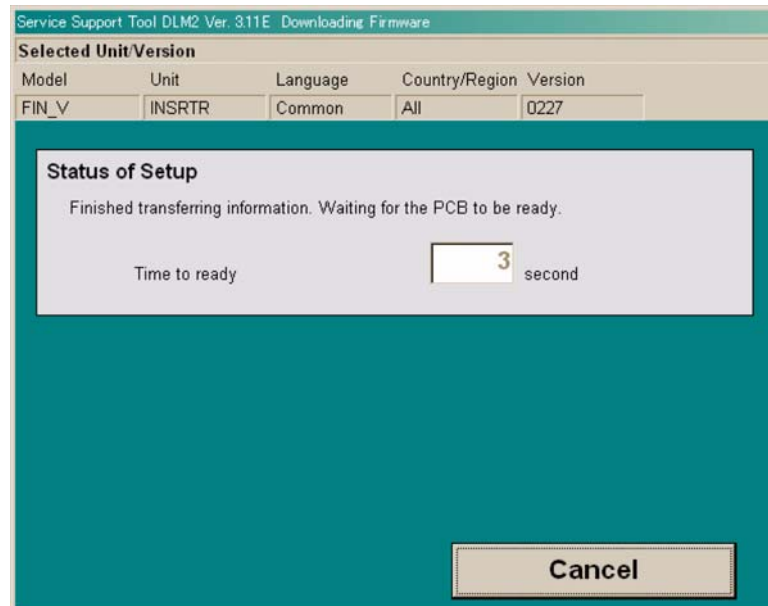

F-4-22

8) Press the [OK] key when the download is properly completed.

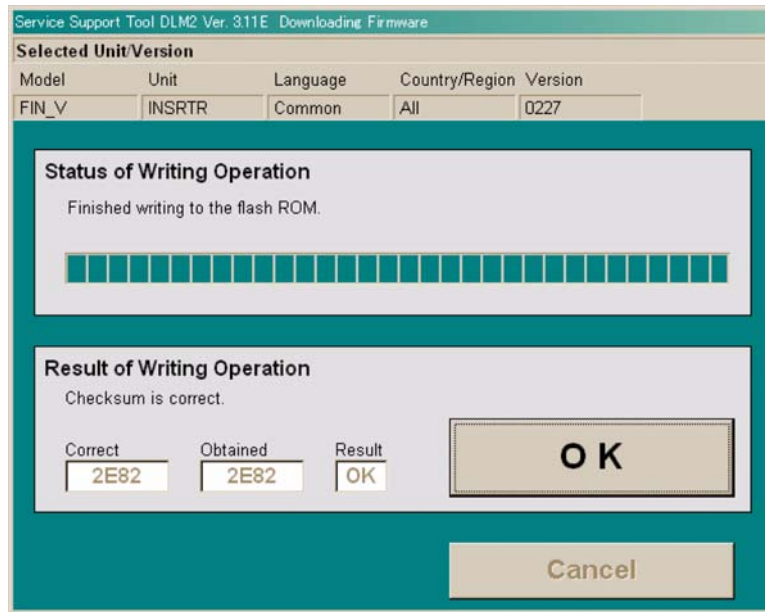

F-4-23

9) Follow the screen to end.

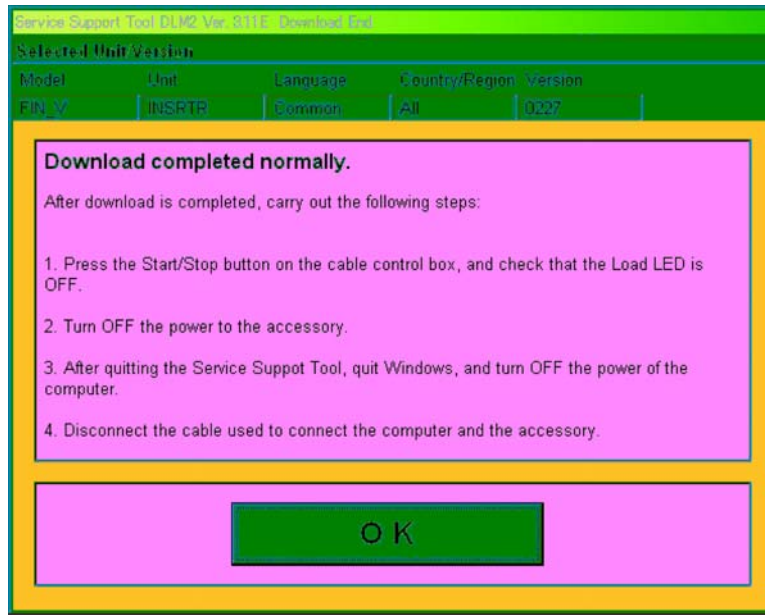

F-4-24

5. Disconnection
- 1) Press the [START/STOP] key. The LOAD LED will go out.
  - 2) Turn OFF the machine.
  - 3) Disconnect the cable B from the inserter.
  - 4) Attach the inserter rear cover.
  - 5) Turn ON the machine.

---

## Chapter 5 Error Code

---





# Contents

5.1 Overview .....	5-1
5.1.1 Overview .....	5-1
5.2 Service Error Code .....	5-1
5.2.1 Service Error Code .....	5-1
5.3 Jam Codes .....	5-1
5.3.1 Jam Code List .....	5-1



## 5.1 Overview

### 5.1.1 Overview

The CPU on the machine's inserter controller is equipped with a self-diagnostic mechanism to check its condition. It runs a check as necessary and, upon detection of a fault, communicates the fact to the host machine using a "code" and a "detail code," which will be indicated in the host machine's control panel. These codes may be checked using the host machine's service mode.

## 5.2 Service Error Code

### 5.2.1 Service Error Code

T-5-1

Error code	Detail code	Error location	Description
E503	8005	Communication	An error has been detected in the communication between the finisher and the inserter.
E505	8005	EEPROM	An attempt to read data from EEPROM has failed.
	8006		An attempt to write data to EEPROM has failed.
E515	8001	Drive switchover motor	The switchover gear did not leave the home position of the drive switchover sensor even after the drive switchover motor had run for a specified time.
	8002		The switchover gear did not reach the home position of the drive switchover sensor even after the drive switchover motor had run for a specified time.
E515	8003	Tray A lift motor	Tray A did not leave the home position even after the tray A lift motor had run for a specified time.
	8004		Tray A did not reach the home position even after the tray A lift motor had run for a specified time.
E515	8005	Tray B lift motor	Tray B did not leave the home position even after the tray B lift motor had run for a specified time.
	8006		Tray B did not reach the home position even after the tray B lift motor had run for a specified time.
E515	8007	Document width sensor	An invalid value was detected by the tray A paper width sensor or the tray B paper width sensor.

## 5.3 Jam Codes

### 5.3.1 Jam Code List

T-5-2

Jam Codes	Name	Sensor No.	Description
1062	Tray A registration sensor delay jam	S5	The tray A registration sensor did not detect presence of paper when a specified time had lapsed since paper pickup had started.
1163	Tray A registration sensor stationary jam	S5	The tray A registration sensor did not detect absence of paper during paper feed after this sensor had detected presence of paper.
1064	Tray B registration sensor delay jam	S13	The tray B registration sensor did not detect presence of paper when a specified time had lapsed since paper pickup had started.
1165	Tray B registration sensor stationary jam	S13	The tray B registration sensor did not detect absence of paper during paper feed after this sensor had detected presence of paper.
1066	Feed sensor delay jam	S14	The feed sensor did not detect presence of paper when a specified time had lapsed since paper had moved past the registration sensor.
1167	Feed sensor stationary jam	S14	The feed sensor did not detect absence of paper during paper feed after this sensor had detected presence of paper.
106A	Feed sensor 2 delay jam	S18	The feed sensor 2 did not detect presence of paper when a specified time had lapsed since paper had moved past the feed sensor.
116B	Feed sensor 2 stationary jam	S18	Feed sensor 2 did not detect absence of paper during paper feed after this sensor had detected presence of paper.
1F70	Tray A paper absence jam	S1	A paper pickup request signal was received when there is no paper in tray A.
1F71	TrayB paper absence jam	S6	A paper pickup request signal was received when there is no paper in tray B.
1F72	Paper size mismatch jam	S7	The paper size detected during paper feed was different from the reported paper size.
1374	Power-on jam	S5,S13,S14,S18	Paper was detected in the inserter's feed path at power-on.
1475	Door open jam	S15,S17	The cover was opened during inserter operation.



Feb 7 2006

**Canon**